



Efficient storage systems

PRODUCT TECHNICAL FILE



COMPACT PALLET RACKING (DRIVE IN/THROUGH)

CONTENTS

	Page
1. SCOPE	2
2. PRODUCT DESCRIPTION	2
2.1. Materials	5
2.1.1. Steels	5
2.1.2. Finishes	6
2.2. Structural elements	7
2.2.1. Frames	7
2.2.2. Bracings	7
2.2.3. Uprights	12
2.2.4. Additional frame components	14
2.2.5. Spacers	15
2.2.6. Loading levels	15
2.2.7. Stiffening elements	21
2.2.8. Optional elements	24
2.2.9. Fastening elements	27
3. TECHNICAL REPORT	28
4. LOADING CAPACITIES	30
5. GUARANTEE	31
6. STANDARDISATION AND CERTIFICATIONS	32
7. AFTER-SALES SERVICES	33

1. SCOPE

Esterias Record, S.L. designs and manufactures several types of metal racking, shelving and storage systems in compliance with applicable standards. Therefore, we have to document the specifications and characteristics of each product line to create a summarised view of the theoretical parameters and structural and functional elements considered in each particular solution.

This product file aims to provide a general description of the COMPACT PALLET RACKING system.

It develops an outline of the individual components in the system and the different possibilities to combine them to create the structures which must bear the load of the stored goods. We also describe the materials used to manufacture the components and any other accessories incorporated in the specific, unmodified solution. Finally, it includes a normative justification of the product design calculations and the load-bearing capacities of the product's main elements.

The scope of this report is not exhaustive, but rather it is purely descriptive and aims to provide a broad view of the system's general operation. It is not intended, therefore, to explain all the combinations of uses and components in meticulous technical detail, as this would go beyond the purposes for which it has been conceived; it has been created as an educational, supporting material, so its content should not be considered as a definitive and accurate reference, but rather instructional.

This technical file has been edited strictly in line with the aforementioned objectives. The information it contains is private and must not be subject to distribution, processing, reproduction or transfer of use without the prior express permission of Esterias Record, S.L. who reserves all of their rights.

The information in this document may be altered without prior notice because of changes related to the products' manufacturing characteristics, because of technical or functional obsolescence of certain elements which may be replaced with others, or because of other adequately justified modifications which have a direct or indirect impact on the content of the text.

2. PRODUCT DESCRIPTION

The storage system constitutes an appropriate combination of its structural elements according to the technical and functional parameters for its planned use.

The system's basic components are the frames and loading levels. These and some other components are described in more detail below.

The frames are arranged parallel to each other forming lanes so that forklifts can drive into the structure.

Corbels are fitted onto the frame's uprights in order to support the rails over which the pallets are distributed, thereby creating a loading level for storing goods.

The volume between two vertically adjacent levels defines the maximum load and the dimensions and number of pallets allowed per level.

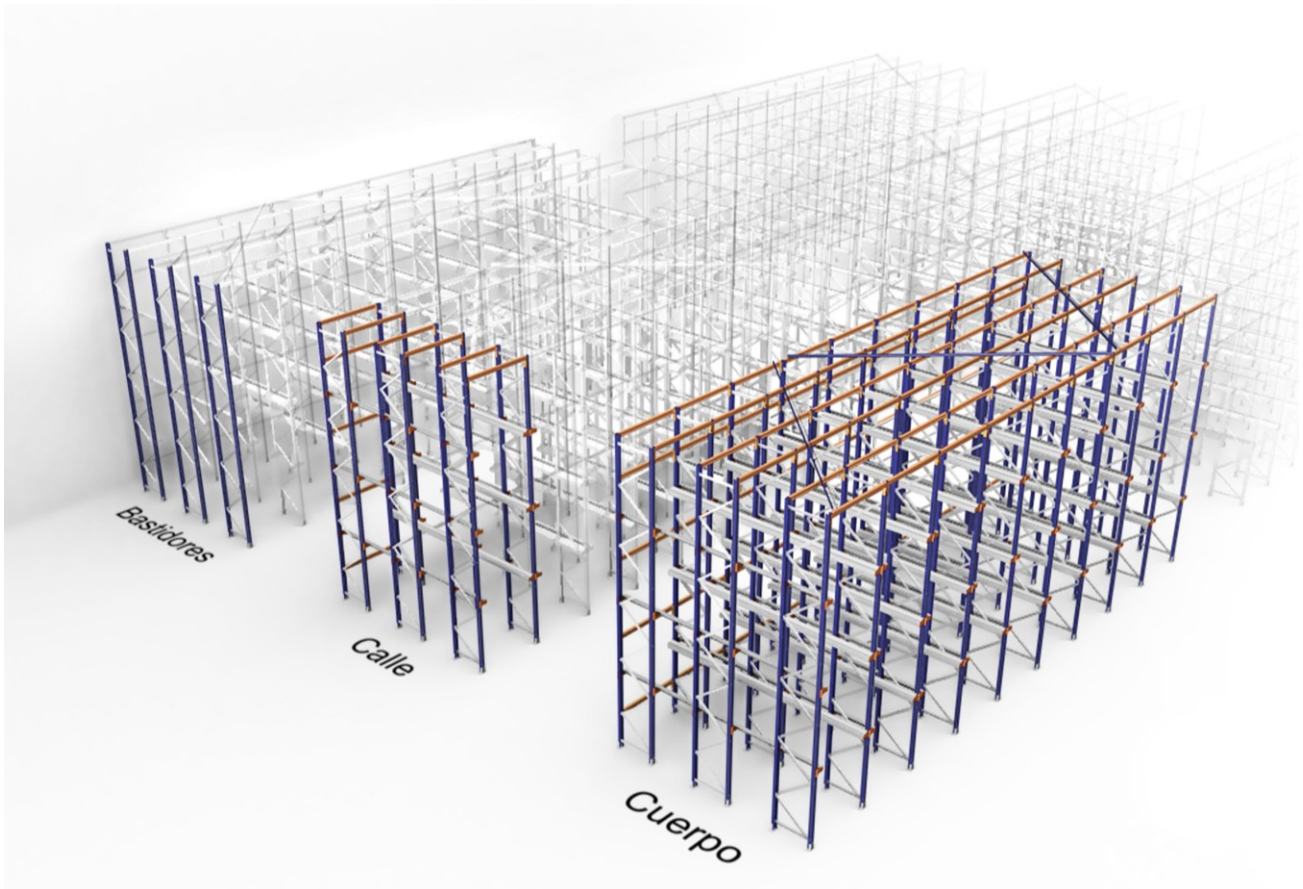

Each structural system containing various lanes and loading levels is called a block. Each block can have a single entrance, if the structure is close to a wall, or a double entrance, if it is accessible from both ends at the same time. Dual access blocks double the system's performance by accelerating stock rotation.

The structure is stiffened at the top and rear using beams and bracings to control longitudinal and transverse thrusts produced by the loads and the system's functional circumstances.

Lines of parallel blocks form intervening aisles whose width is determined by the applicable standards, by the handling equipment available, and by the means of access to and dimensions of the unit loads.

Main advantages:

- Constitutes the most appropriate solution for dense storage of uniform products with moderate rotation and a low obsolescence rate. Ideal for LIFO (last in first out) warehouse management methods and situations where space constraints take priority over stock selectivity and rotation.
- As the compact storage system dispenses with access and handling aisles, it is guaranteed to take full advantage of the usable area available (between 60% and 80%). This means the goods can be stored very densely by forming an accumulated storage block that fully optimises use of the warehouse's cubic space.
- Easily adapted as requirements change. The range of accessories and configurations means the storage system can be adapted for use with uniform loads of all weights and volumes.

- Strict control over stored goods and the flow of circulation and service, contributing to methodical, organised logistics management. Particularly productive when operating with a limited variety but a high quantity of products by organising each loading level with a single group of items with uniform characteristics.
- As the system's structural elements follow an excellent assembly design it can be disassembled and relocated quickly. Alternatively it can be reconfigured or amplified according to new storage needs. Furthermore, damaged components can be replaced easily and immediately.
- Optimum use of the vertical space. Loading levels can be adjusted quickly and easily to adapt to different volumes of stored goods.
- Versatility and flexibility of use saves time and effort, thereby preventing warehouse management errors. The system's configuration options mean the racks can be used in coordination with any type of handling equipment used in the warehouse.

The user can rest assured that their investment will never become obsolete and that it can evolve and develop in parallel with their business. Once Esterias Record have completed the appropriate studies, the installed storage system can be reconfigured, expanded or refurbished as and when new circumstances or expansion or relocation requirements arise.

The conventional system for compact pallet racking is designed to optimise stock management and maximise warehouse usage through a controlled investment that is proportional to the benefits and advantages it will bring.

The following diagrams provide an example of the design:





2.1. MATERIALS

Sections are cold-formed and punched from steel strips before they undergo electrostatic painting in a continuous flow, phosphate, anticorrosive coating and oven curing treatments.

The load-bearing capacity of the racks is determined directly by the type and quality of steel used in their construction, which is established by the applicable standard, and by the physical characteristics and behaviour of each configuration in response to elastic instability phenomena associated with the individual elements and the structural systems formed from combinations thereof.

2.1.1. Steels

The quality of the steels used to manufacture the different elements varies depending on the structural requirements of the specific solution.

All the pickled steel strips used to manufacture the sections are certified at source.

Depending on each element's end use, nominal values for yield stress, f_y , range between 235 N/mm^2 and 355 N/mm^2 , in accordance with standard EN 10025.

Values for ultimate tensile strength, f_u , vary from 360 N/mm^2 to 510 N/mm^2 , as per standard EN 10025.

They are guaranteed to have the following mechanical characteristics:

Property	Value
Elastic modulus	$E = 210000 \text{ N/mm}^2$
Shear modulus	$G = E/2(1+\nu) \text{ N/mm}^2$
Poisson's ratio	$\nu = 0.3$
Coefficient of linear thermal expansion	$\alpha = 12 \times 10^{-6} \text{ }^\circ\text{C}$
Density	$\rho = 7850 \text{ Kg/m}^3$

The system's metal elements are grade A1 (M0), according to certification at source, in compliance with Spanish Royal Decree 2267/2004, dated December 3, which approved the fire safety regulations in industrial premises. Elements with a zinc coating of less than 100 μm have a fire rating of M1, class B-s3,d0, in accordance with standard UNE-EN 13501-1:2007.

2.1.2. Finishes

All ungalvanised elements are painted to obtain a surface finish using an automated, double rail, continuous flow process with several treatment stages: cleaning, degreasing, phosphating, anticorrosive coating, pigment spraying and curing. Pieces are degreased before painting by means of phosphate and passivation treatments. A thermosetting epoxy polyester paint is then applied using a robotised electrostatic sprayer and oven cured immediately at 200 $^\circ\text{C}$ for 15 minutes.

This produces a glossy, uniform coating approximately 65 μm thick with a high impact, wear and corrosion resistance, a fire rating of M1, in accordance with standard UNE 23727-90, certified at source, tested according to standards UNE-EN 13823:2002 and UNE-EN ISO 11925-2:2002, and classified in line with UNE-EN 13501-1:2007 B-s2,d0, both certified at source. The coatings' mechanical specifications are presented below:

Property	Standard	Result
Gloss	ISO 2813	84
Adhesion	ISO 2409	GTO
Direct and reverse impact	ISO 6272	70 cm
Cupping	ISO 1520	7 mm
Bend test	ISO 1519	5 mm
MEK	IC-101	100 DF
Salt spray hours		500

Vertical elements are painted blue (RAL 5003) and horizontal ones orange (RAL 2009), while all other components are made from galvanised steel.

Like the paints, all other auxiliary materials used to manufacture the system's elements are selected according to the specifications and requirements of applicable standards, their production and reception processes are certified, and they are constantly subjected to the tests and inspections established by the quality assurance and management procedures in ISO 9001:2008.

2.2. STRUCTURAL ELEMENTS

2.2.1. Frames.

The frames correspond to the structure's basic vertical elements. Each frame comprises two uprights connected by a series of horizontal and diagonal bracings secured with grade 8.8 DIN 931 M8x65 / M8x90 bolts. The bolts are made from high strength steel and fitted with DIN 985 self-locking safety nuts and Teflon® washers to ensure they do not become loose with use.



Height (mm)	Depth (mm)
2,000	500
2,500	600
3,000	800
3,500	900
4,000	1,000
4,500	1,100
5,000	1,200
5,500	1,300
6,000	1,400
6,500	1,500
7,000	
7,500	
8,000	
8,500	
9,000	
9,500	
10,000	
10,500	
11,000	
11,500	
12,000	

This structure will bear the axial compression load in service conditions and transmit it to the floor. They are also subject to the lateral thrust produced by the mechanical forces acting in the system.

2.2.2. Bracings or trusses

Steel sections with a guaranteed minimum grade of DC01, while higher grades, DC03 and DC04, may be used as per standard UNE-EN 10130. All bracings are C-sections with dimensions of 40x28x9.2 mm and 9 mm diameter holes drilled at both ends. Their length depends on the depth of the frame.

The horizontal and diagonal bracings are appropriately triangulated. Intersections between diagonal and horizontal bracings, or those between two diagonal elements, are fixed to uprights using DIN 931 M8x65 or M8x90 bolts with DIN 985 M8 self-locking nuts.

The following diagram shows the start of the bracing structure.

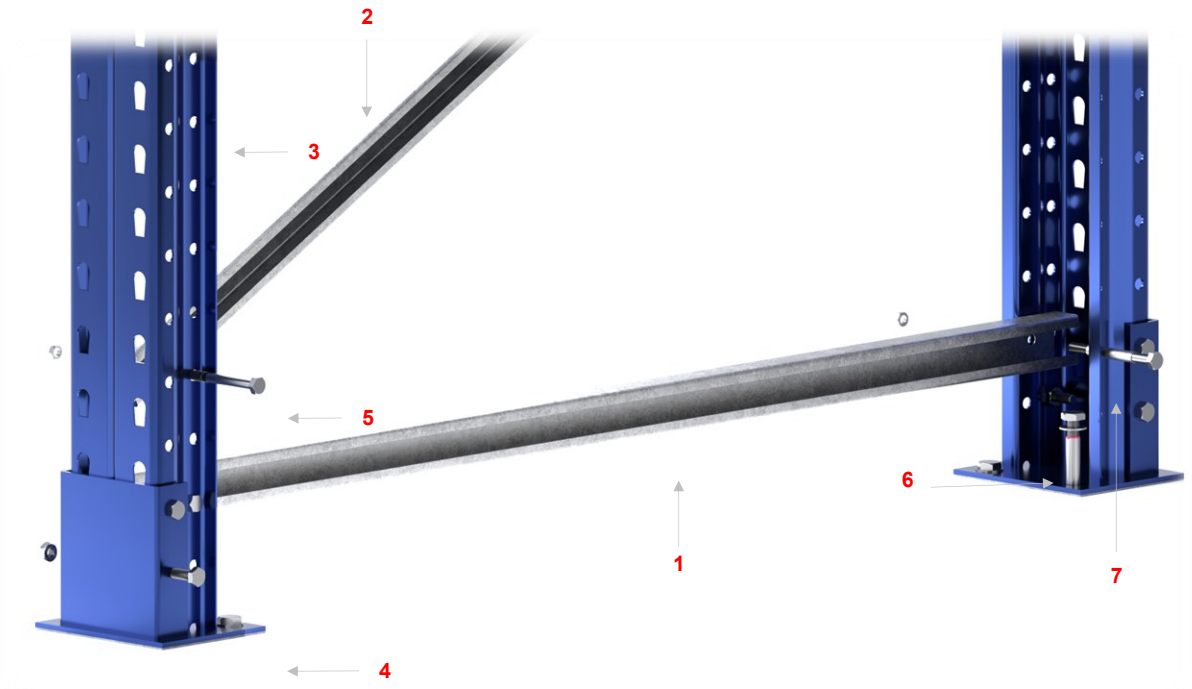

No.	Description
1	Horizontal bracing
2	Diagonal bracing
3	Upright
4	Base plate

No.	Description
5	M8x65 / M8x90 bolt (*)
6	Anchor bolt
7	Spacer fitting

(*) M8x90 metric bolts are only used when the frame is constructed with 100 63 uprights, all other assemblies are secured with M8x65 bolts.

The distance between diagonal bracings is fixed at 550 mm for all frames, which gives a maximum span between trusses of 1,100 mm. The angles between diagonal bracings generally ranges from 20° to 70°.

The free ends of the horizontal and diagonal bracings (where there aren't any nodes) are bolted to the uprights. Spacer fittings are used to prevent any slack between bracings and the upright. These are hollow rectangular parts measuring 14x14 mm and 51 mm long which fill the gap between the bracing and the upright.

The diagram below shows how the components are arranged in the structure explained above, as well as the assembly dimensions and details for each frame height:

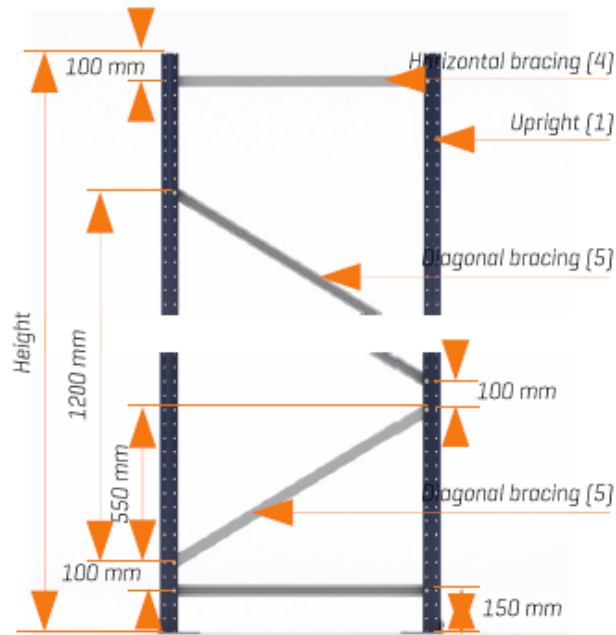

Type 1 assembly scheme

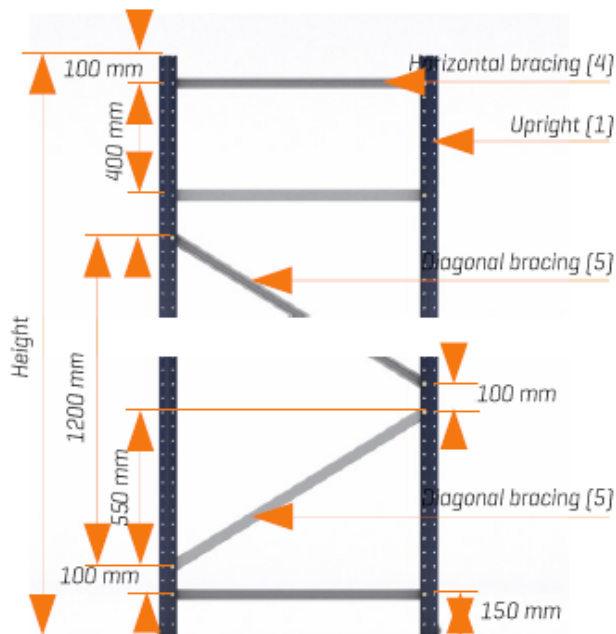

Type 2 assembly scheme

The table below shows the bracing components for each height of frame described above. However, this may depend on the specific requirements that define the design of each particular solution.

Height (mm)	Uprights Units	Base plates Units	Plate bolts Units	Spacer fittings Units	Horizontal bracings Units	Diagonal bracings Units	Bolts (*) Units
2,000	2	2	4	8	2	2	8
2,500	2	2	4	10	2	3	10
3,000	2	2	4	12	2	4	12
3,500	2	2	4	12	2	4	12
4,000	2	2	4	14	2	5	14
4,500	2	2	4	16	2	6	16
5,000	2	2	4	18	2	7	18
5,500	2	2	4	20	3	7	20
6,000	2	2	4	22	3	8	22
6,500	2	2	4	22	2	9	22
7,000	2	2	4	24	2	10	24
7,500	2	2	4	26	3	10	26
8,000	2	2	4	28	3	11	28
8,500	2	2	4	28	2	12	28
9,000	2	2	4	30	2	13	30
9,500	2	2	4	32	2	14	32
10,000	2	2	4	34	3	14	34
10,500	2	2	4	34	2	15	34
11,000	2	2	4	36	2	16	36
11,500	2	2	4	38	2	17	38
12,000	2	2	4	40	3	17	40

(*) Length varies depending on the type of strut.

The diagrams below show the different types of node and illustrate whether or not spacer fittings need to be fitted.

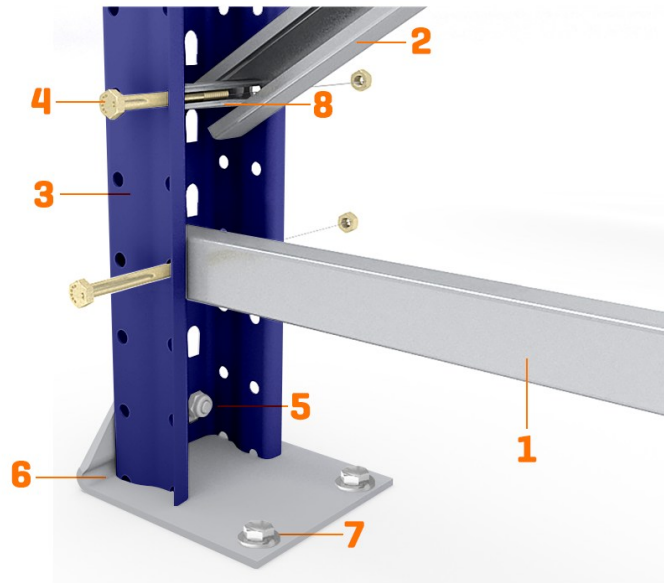

Detailed diagram of bracing elements

No.	Description	No.	Description
1	Horizontal bracing	5	M10x20 bolt
2	Diagonal bracing	6	Base plate
3	Upright	7	Anchor bolt
4	M8x65 / M8x90 bolt	8	Spacer fitting

(* M8x90 metric bolts are only used when the frame is constructed with 100 63 uprights, all other assemblies are secured with M8x65 bolts.

Dimensions of horizontal and diagonal bracings:

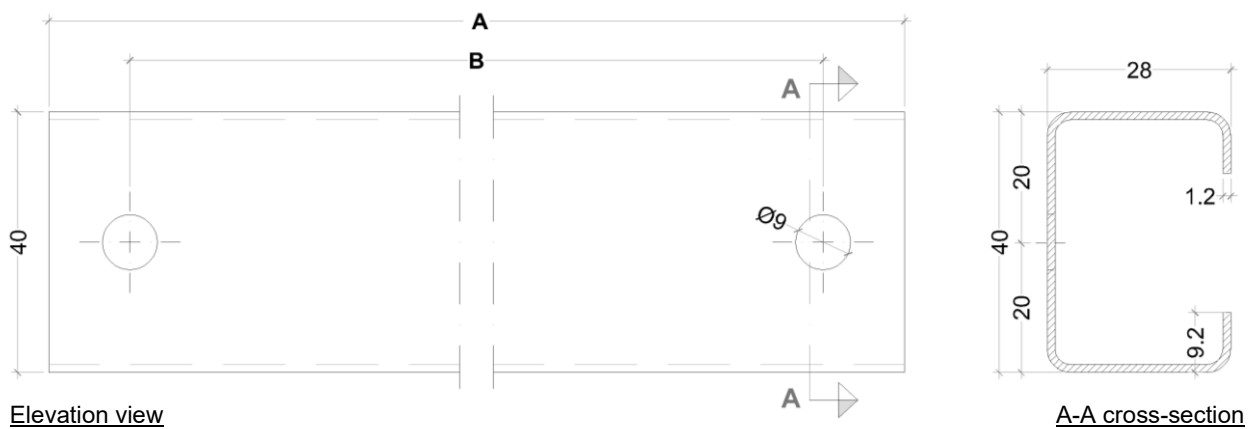

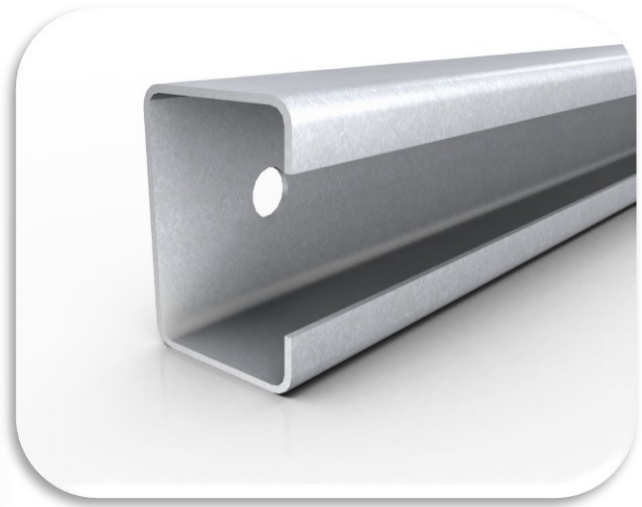
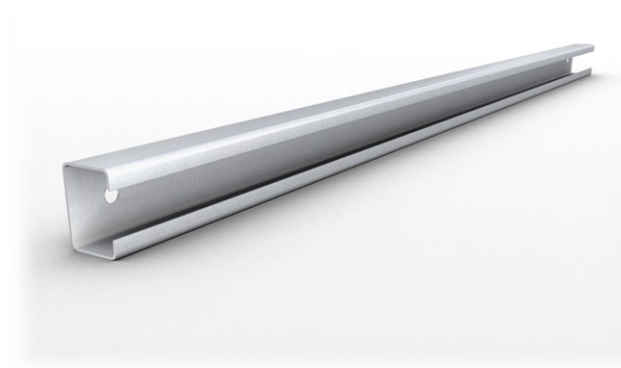
Horizontal/diagonal bracings
Diagonal bracings (mm)

Frame depth	Upright 80 63/100 63		Upright 100 100	
	A	B	A	B
500	730	680	693	643
600	793	743	750	700
800	940	890	889	766
900	1,021	791	966	824
1,000	1,105	1,055	1,048	998
1,100	1,191	1,141	1,133	1,083
1,200	1,280	1,230	1,220	1,170
1,300	1,370	1,320	1,309	1,259
1,400	1,462	1,412	1,400	1,350
1,500	1,554	1,504	1,492	1,442

Horizontal bracings (mm)

Frame depth	Upright 80 63/100 63		Upright 100 100	
	A	B	A	B
500	450	400	383	333
600	550	500	483	433
800	750	700	683	633
900	850	800	783	733
1,000	950	900	883	833
1,100	1,050	1,000	983	933
1,200	1,150	1,100	1,083	1,033
1,300	1,250	1,200	1,183	1,133
1,400	1,350	1,300	1,283	1,233
1,500	1,450	1,400	1,383	1,333

2.2.3. Uprights

Hot-rolled, as per standard EN 100252:2004, and cold-formed S235JR to S355JR grade steel C-sections, with an appropriate thickness for the load they must bear.

They feature two lines of holes, each separated by 50 mm, along their front surface; the connectors for the load-bearing beams slot into these holes. There are also two rows of holes, measuring 9 mm in diameter and again separated by 50 mm, facing each other on both sides of the uprights. These holes are used to attach the bracings.

As detailed above, the holes in the front of the uprights can be used to graduate the loading level every 50 mm.

Each flat element subject to compression is duly stiffened to ensure it performs correctly in case it gets dented. To this end, the uprights have nine longitudinal pleats which confer excellent stiffness against these

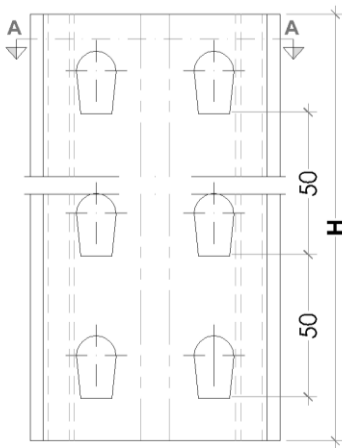

Plan view Upright 80 63

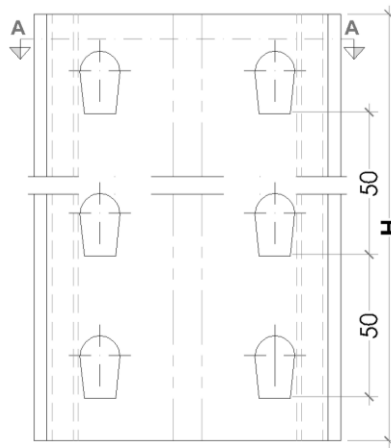

Plan view Upright 100 63

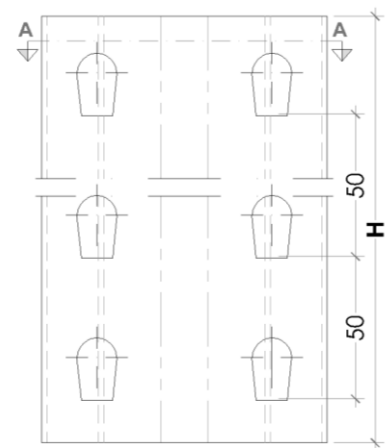

Plan view Upright 100 100

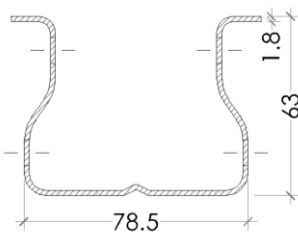

Plan view Upright 80 63

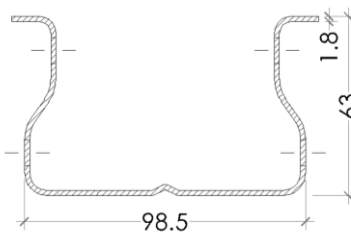

Plan view Upright 100 63

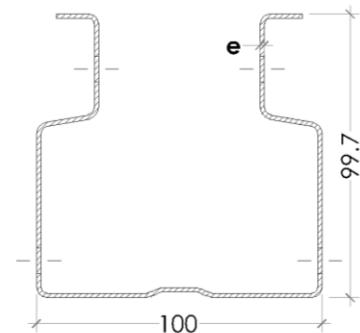

Plan view Upright 100 100
e = 1.5 / 1.8 / 2.0 mm

phenomena; these pleats have been especially designed so that their inertia in function of their width, length and thickness ensures the structure is sufficiently stiffened for the service conditions which it must endure.

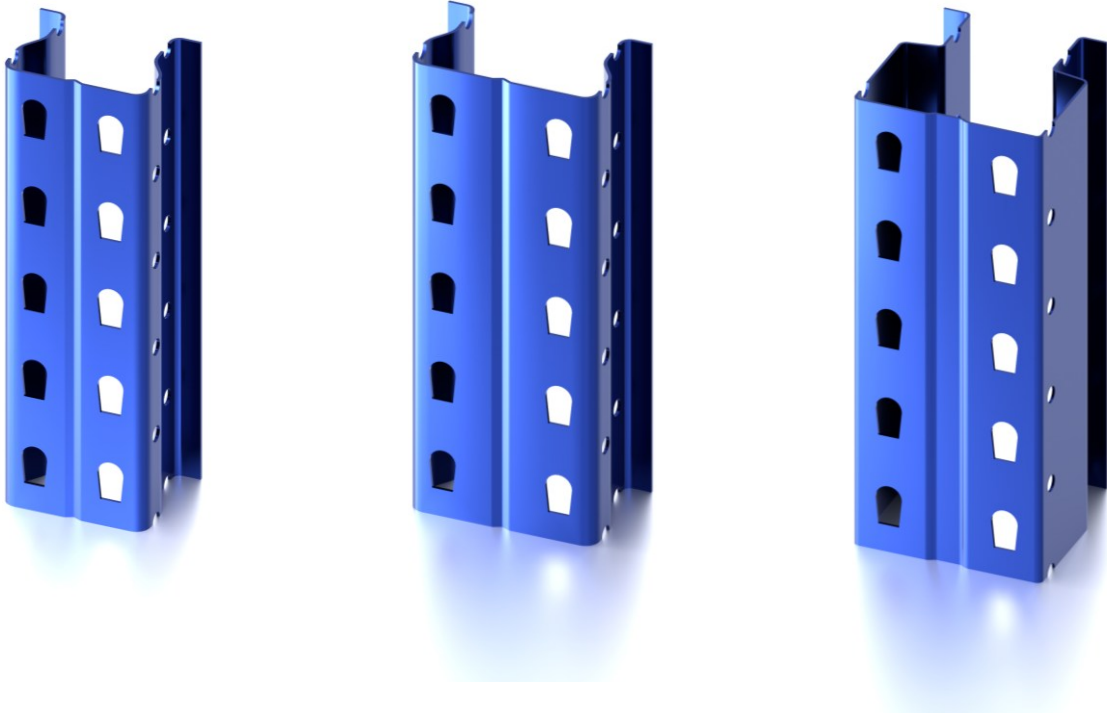

Uprights 80 63, 100 63 y 100 100

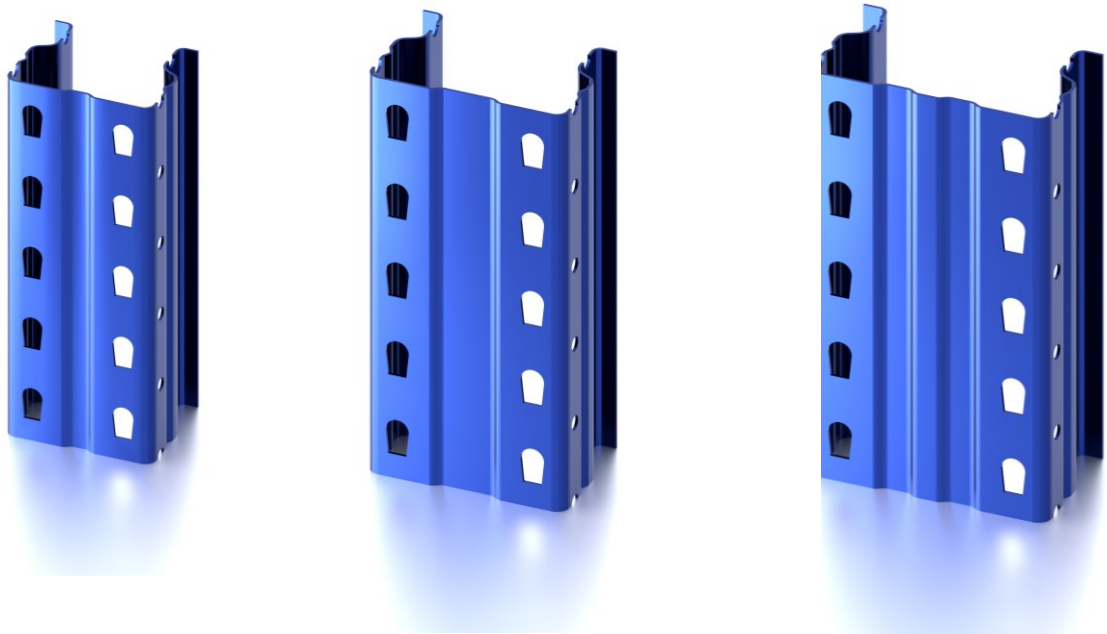

Uprights 100 80, 120 80 y 140 80

2.2.4. Additional frame components

Each upright is fitted with a metal foot especially designed to transmit the load to the floor and control any punching shear or settlement phenomena in the underlying concrete. This is also affected by the dimensions and characteristics of the concrete floor slab.

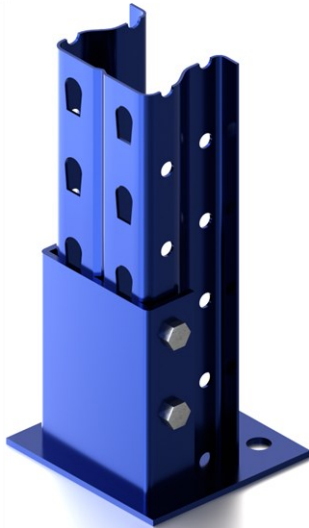

Upright 80 63 with base plate

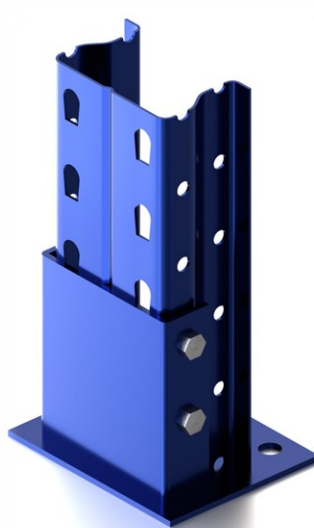

Upright 100 63 with base plate

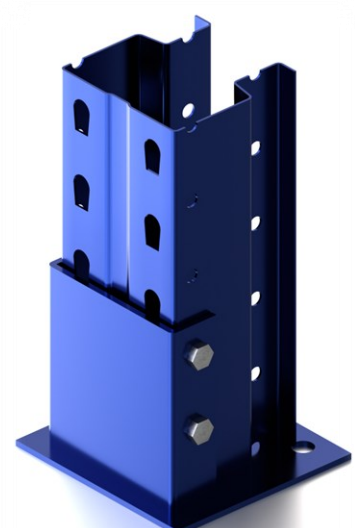

Upright 100 100 with base plate

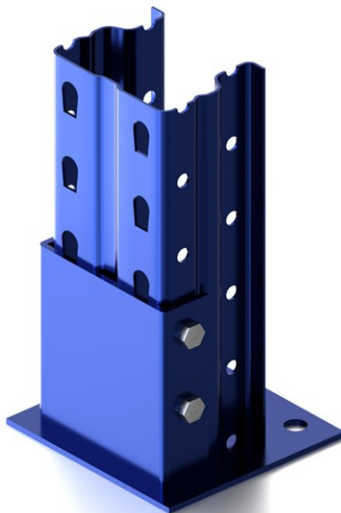

Upright 100 80 with base plate

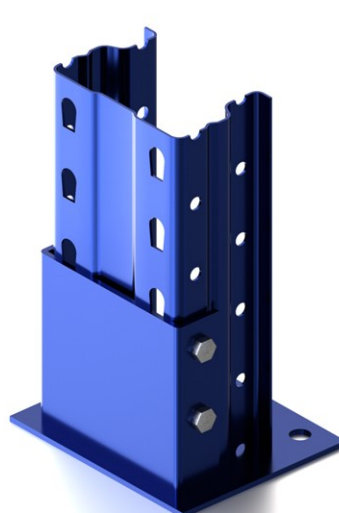

Upright 120 80 with base plate

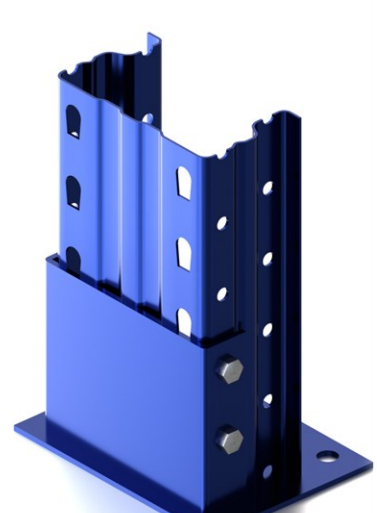

Upright 140 80 with base plate

The surface supporting the racking system must always be of sufficient quality and strength to bear the maximum loads for which the system has been designed. Concrete reinforced with a 4 mm diameter metal mesh measuring 150x150 mm, at a minimum thickness of 150 mm, and with an allowable compressive strength of M200 (200 kg/cm²), or greater, is acceptable for these loads.

What is more, it must be perfectly levelled to ensure the vertical elements are plumbed correctly. Therefore, the maximum permissible unevenness between any two points of the slab must not exceed ± 10 mm.

Lastly, and depending on the condition of the concrete floor slab, a levelling plate shall be fitted between the base plate and the floor to correct any unevenness and plumb the frame.



2.2.5. Spacers

Frame spacers. These join together the rows of frames that make up the depth of a lane and help strengthen the structure against mechanical instability. They are attached to the frame uprights using four M8x15 bolts.



Frame spacer

Nominal length of frame spacers (mm)

100	400	700	1,000	1,300
150	450	750	1,050	1,350
200	500	800	1,100	1,400
250	550	850	1,150	1,450
300	600	900	1,200	1,500
350	650	950	1,250	

2.2.6. Loading levels

Corbels, in combination with centring rails, are the basic elements constituting the loading levels in the compact pallet racking system. The single/double corbel beams complete the structural system in each loading level. Corbels are designed to transfer the load to the frames; there are both double and single corbels, the latter available as left and right versions based on their location in the structure. Depending on load requirements and the system's use, there are several types of corbel with different designs and characteristics:

80 corbels. These slot onto 80 63 uprights. They are made from grade DC01 steel plates, while higher grades (DC03 and DC04) may be used as per standards EN 10130 and UNE-EN 10025. Their thickness is adapted to the loads they must bear in each storage system, with the minimum being at least 3 mm.

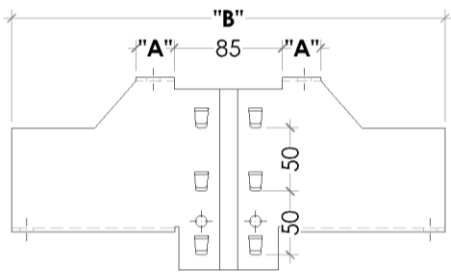

Elevation view of 80 double corbel

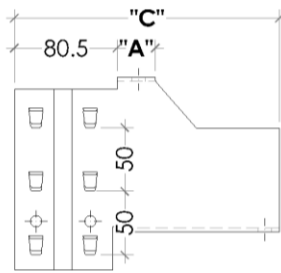

Elevation view of 80 left corbel

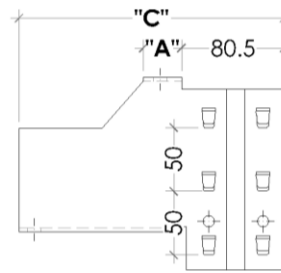

Elevation view of 80 right corbel

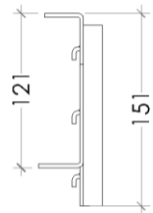

Cross-section 80 corbel

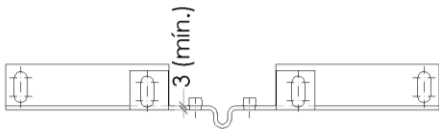

Plan view of 80 double corbel

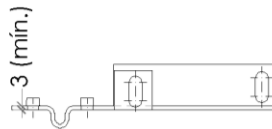

Plan view of 80 left corbel

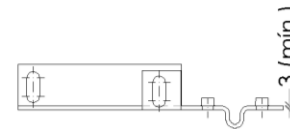

Plan view of 80 right corbel

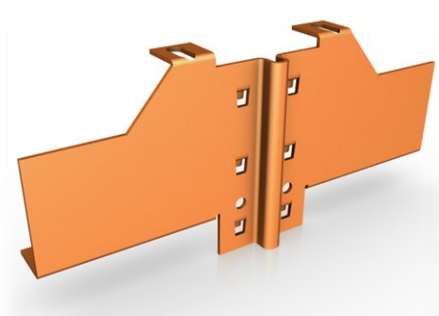

80 double corbel



80 left corbel



80 right corbel

Dimensions for 80 corbels (mm)

Nominal dimension	"A"	"B"	"C"
70	30	340	208
120	80	440	258
170	130	540	308

100 corbels. These slot onto 100 63 and 100 100 uprights. They are also made from grade DC01 steel plates, while higher grades (DC03 and DC04) may be used as per standards EN 10130 and UNE-EN 10025. Their thickness is adapted to the loads they must bear in each storage system, with the minimum being at least 3 mm.

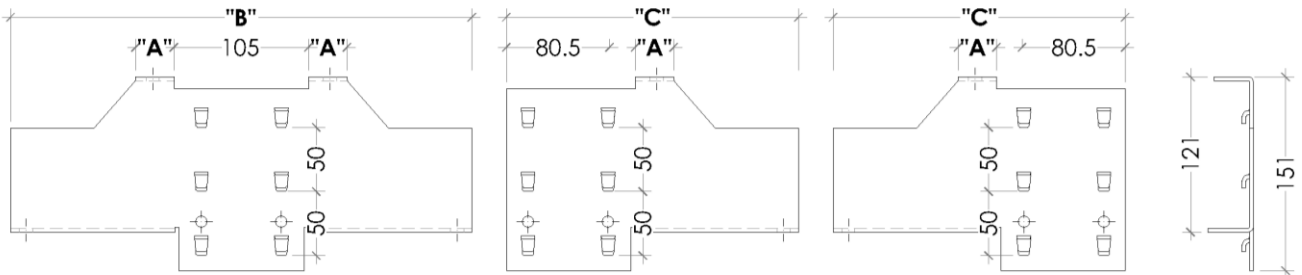

Elevation view of 100 double corbel

Elevation view of 100 left corbel

Elevation view of 100 right corbel

Cross-section 100 corbel

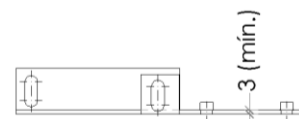
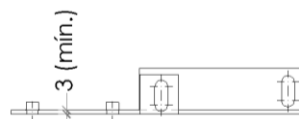
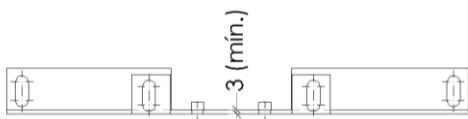

Plan view of 100 double corbel

Plan view of 100 left corbel

Plan view of 100 right corbel

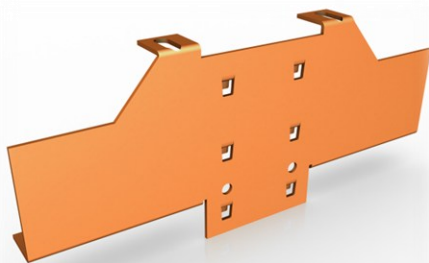

100 double corbel

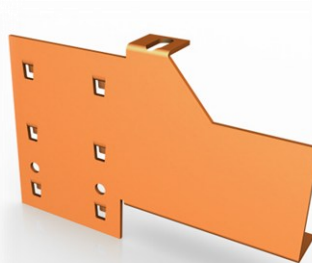

100 left corbel



100 right corbel

Dimensions for 100 corbels (mm)

Nominal dimension	"A"	"B"	"C"
70	30	360	228
120	80	460	278
170	130	560	328

They attach to the frame by means of six 11-mm hooks projecting from each corbel and which fit into the corresponding holes in the uprights. This type of connection is specifically designed to transmit the thrusts from the service load correctly, thus minimising strain in the system and self-centring compressive forces to prevent risks associated with shearing stress.

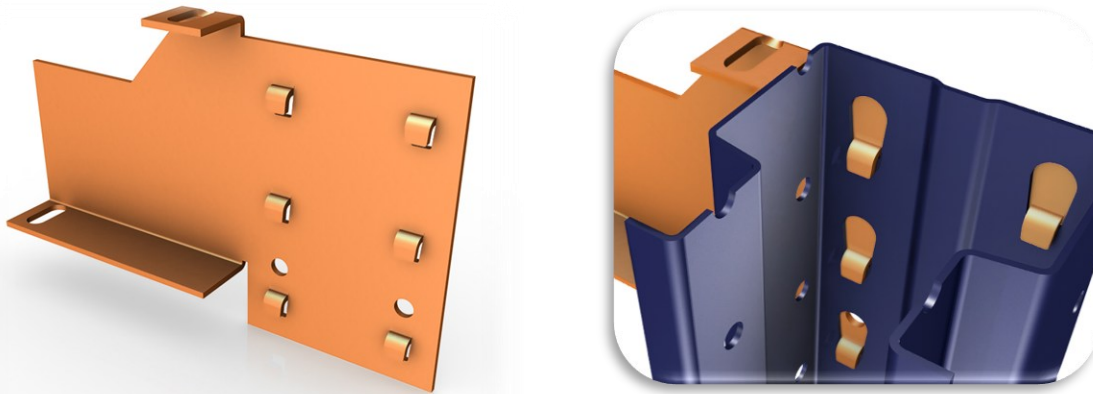

Corbel/upright connections. Close-up of the hooks and position on the upright

Once fixed onto the frame, the corbels are secured with two M8x15 metric bolts. This type of connection prevents the component from suffering accidental vertical displacement due to external thrusts, mainly due to forklift manoeuvres, and helps improve the overall system's behaviour in response to service loads.

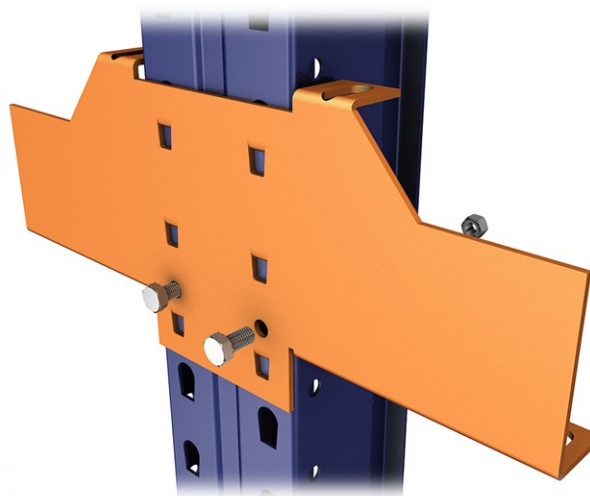

Corbels. Secured with M8x15 bolts

Centring rails. These support and guide the pallets, while also stiffening the structure depthwise. They are constructed from grade ST-02 galvanised steel sheet, in line with standard DIN 17100, with a thickness of 2 mm or more according to load-bearing requirements in each case. They have holes drilled in the top and bottom surfaces so they can be connected to the corbels using M10x20 bolts.

Rails are available in lengths of up to 12,000 mm, with standard pieces cut at 100 mm intervals.



Centring rail

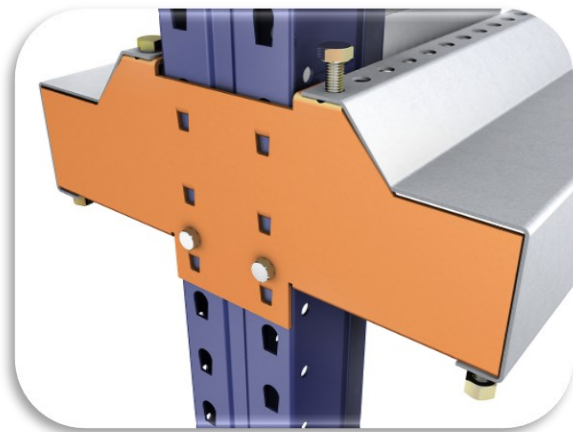

Connection between centring rails and corbels M10x20 bolts

Double corbel beams. These are made up of two C-sections assembled to form a tubular structure, plus two beam corbel connectors and two beam rail connectors, one of each attached to both ends using high-strength welding.

Single corbel beams. These are made up of two C-sections assembled to form a tubular structure, plus two lateral connectors and two beam rail connectors, one of each attached to both ends using high-strength welding.

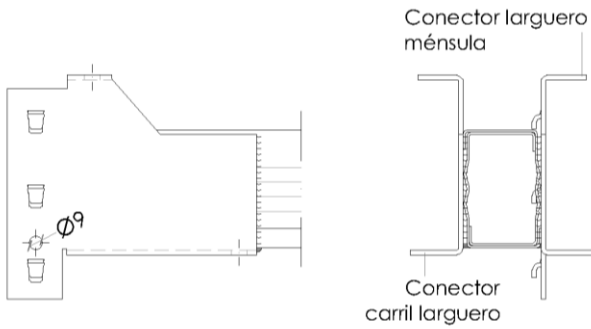

Generic elevation and cross-section
Double corbel beam

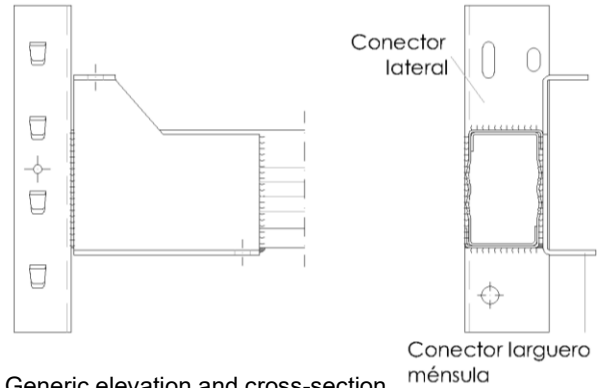

Generic elevation and cross-section
Single corbel beam

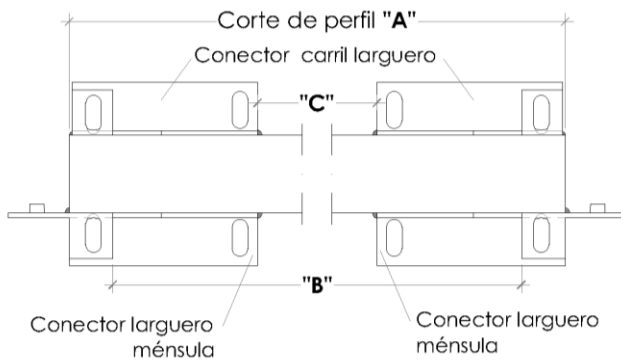

Plan view Double corbel beam

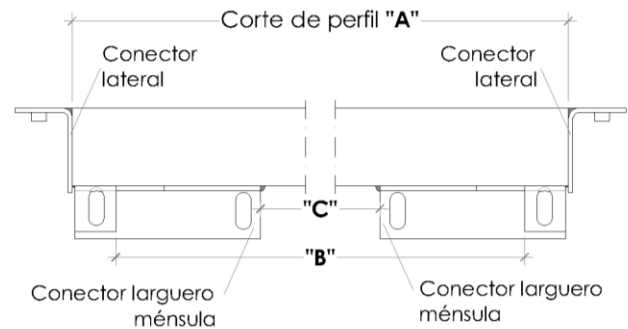

Plan view Single corbel beam

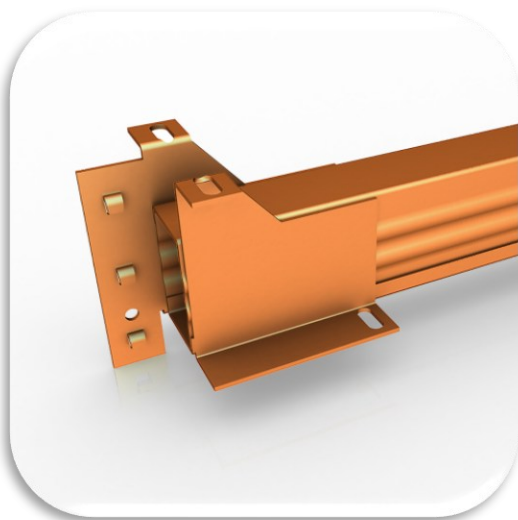

Double corbel beam

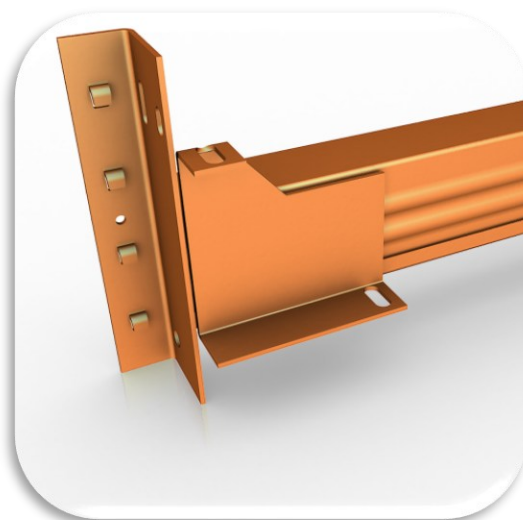

Single corbel beam

Lengths of single/double corbel beams (mm)

Nominal dimension (ND) beam	70 corbel			120 corbel			170 corbel		
	"A"	"B"	"C"	"A"	"B"	"C"	"A"	"B"	"C"
1,150	1,150	1,091	896	1,150	991	796	1,150	891	696
1,250	1,250	1,191	996	1,250	1,091	896	1,250	991	796
1,350	1,350	1,291	1,096	1,350	1,191	996	1,350	1,091	896
1,450	1,450	1,391	1,196	1,450	1,291	1,096	1,450	1,191	996
1,550	1,550	1,491	1,296	1,550	1,391	1,196	1,550	1,291	1,096

These beams are designed to fulfil two functions: they support the pallets in each loading level and provide longitudinal bracing when the overall system requires it. They are positioned towards the back of the block, in the last row of uprights or frames, and at the same height as each of the levels in the configuration.

The beams are attached to the uprights using three 11-mm hooks, projecting from each beam corbel connector, in the case of double corbel beams and four 11-mm hooks projecting from the lateral connector in the case of single corbel beams. They fit onto and are secured to the frames with M8x15 bolts in the same way as described for 80 and 100 corbels.

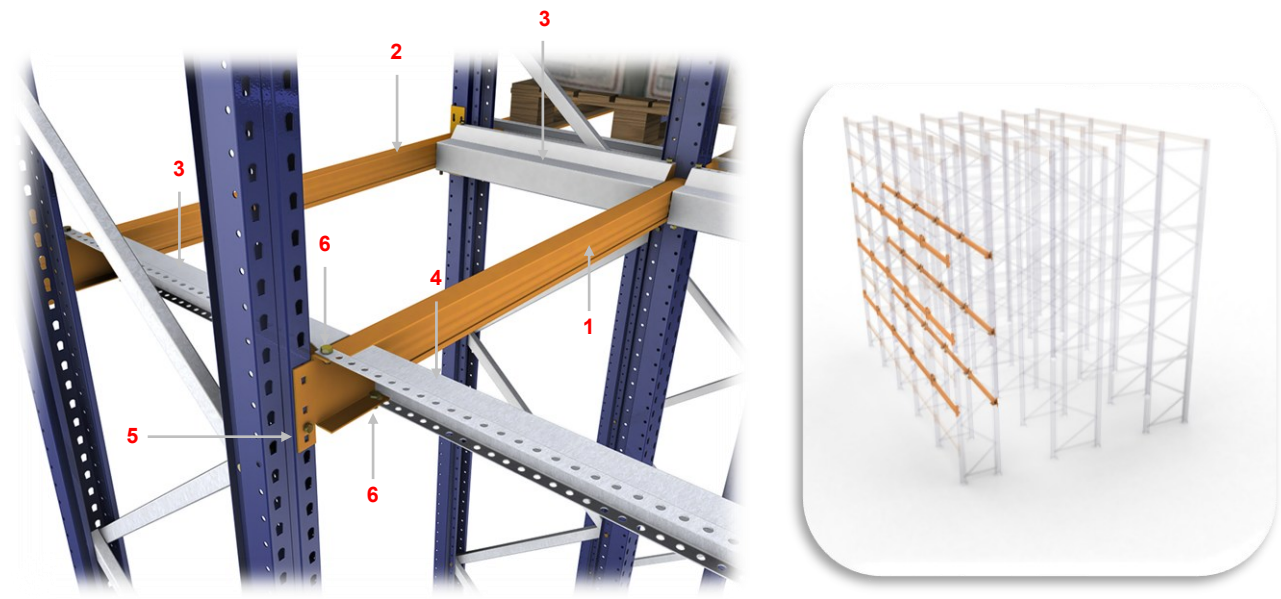

Single/double corbel beams and position in the overall structure

No.	Description
1	Double corbel beam
2	Single corbel beam
3	Centring rail end of lane finish

No.	Description
4	Centring rail
5	M8x15 bolt
6	M10x20 bolt

2.2.7. Stiffening elements

As this storage system operates independently and without transferring forces to pre-existing structural elements, it must be equipped with sufficient stiffness to absorb the thrusts produced by the service load. It is designed with bracing systems that are combined based on the customer's overall requirements, resulting in a very solid and stable structure for the planned function.

Top beams. Top beams are constructed from one U-section with two connectors welded onto both ends so they can slot onto frame uprights. The connector transmits the load acting on the beam to the frame. Connectors are cold-formed L-shaped sections measuring 29x28x3 mm; they are attached to the beam by high-strength robotic welding, so they are very stiff and meet the most demanding tensile strength safety coefficients for the intended use. They have 11-mm hooks that fit into the corresponding holes on uprights and are subsequently secured with M8x15 metric bolts to ensure the top beams do not suffer any vertical displacements due to external thrusts.

This type of connection significantly contributes to the assembly's longitudinal strength and stability, provides a great deal of versatility of use, and minimises assembly/disassembly times.

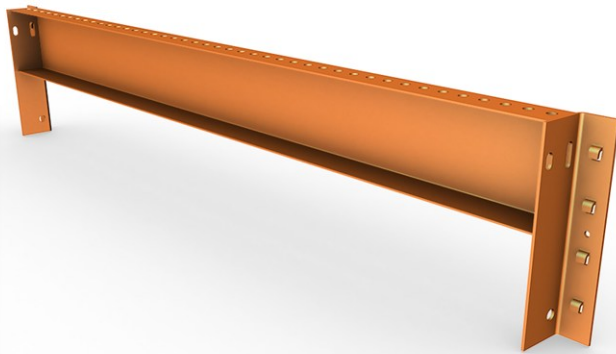

Top beam



Connectors

The top beams are connected to the top end of the uprights on each pair of frames that form the system's lanes, thus creating a gantry that connects the uprights and runs perpendicular to the direction of access to each lane.

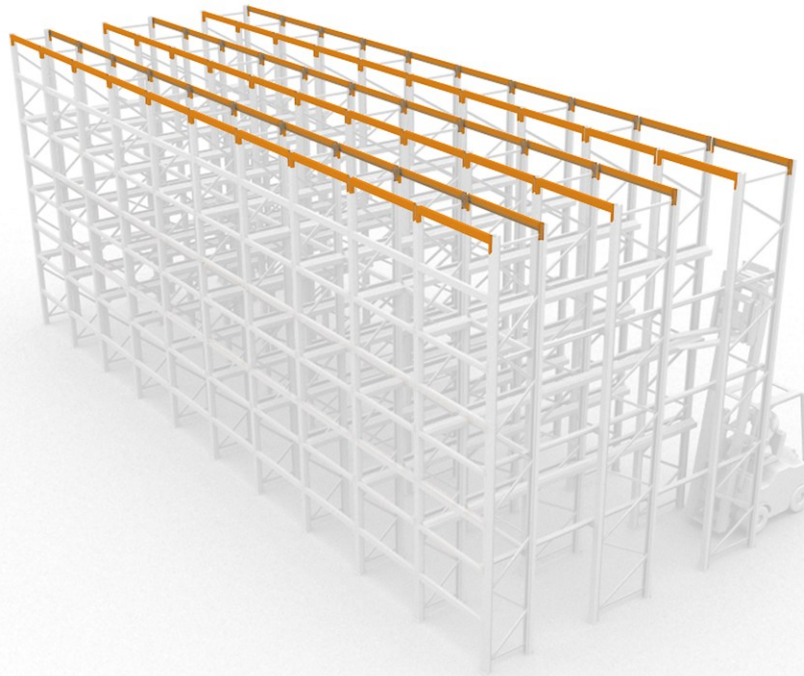

Top beams. Position on top of the structure

When required by the technical solution, the same top beams can also be installed at the back of each lane (again perpendicular to the lane) and distributed at the height of each loading level in the block, thereby reinforcing the longitudinal stability and bracing, and acting as a stop for unit loads.

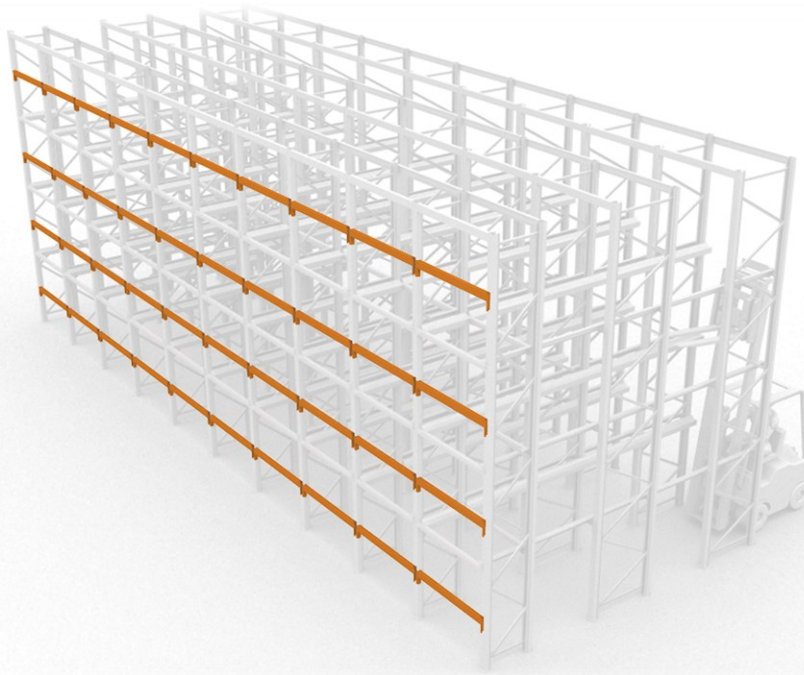

Top beams. Position at the back of the structure

Top bracing. Consisting of C-shaped sections positioned on the top surface of the racking unit, attached to the uprights and arranged transversely to the direction of the aisles. These are fixed to the uprights using M8x15 bolts. The specific length, quantity, arrangement and positioning of these sections within the structure will be determined by an analysis of the particular conditions specific to each installation's design (load to be supported, heights, number of levels, etc.). The bracing described here completes the tensioning and stability of each unit within the racking system.

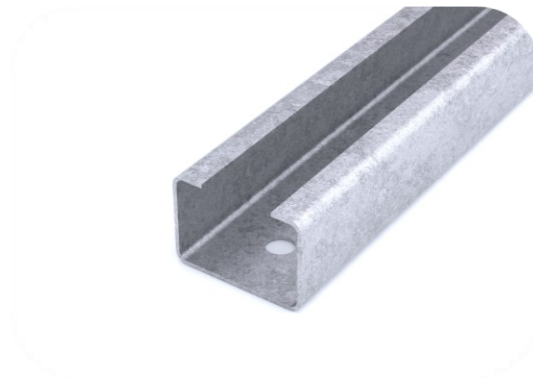

Top bracing



Bracing attachment

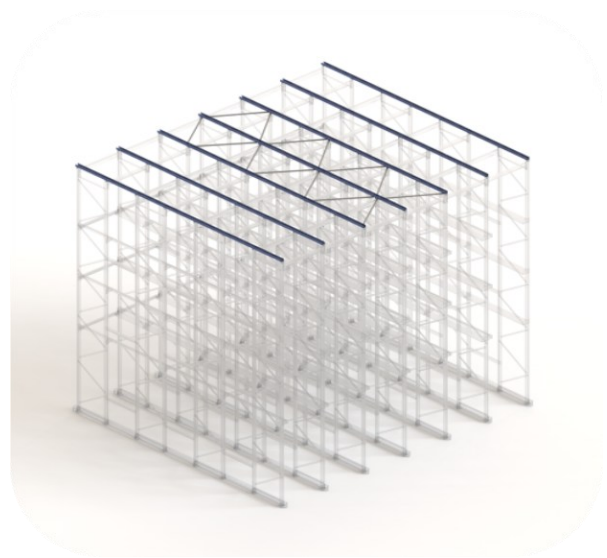

Generic position of bracings

2.2.8. Optional elements

The compact pallet racking system features a wide range of accessories and elements specifically designed for integration into the model described above and to cover diverse requirements depending on the specific conditions of use. Some of these elements are described below:

Upright protectors/reinforcements. These are designed according to the dimensions of the different uprights and to protect them from being struck accidentally by work equipment. Each protector is made from 6 mm DC01 grade sheet metal. They are positioned around the base of uprights located at the entrance to each lane. Protectors are attached using M8x100 bolts for 80 63 uprights or M8x120 for 100 63 and 100 100 uprights, while the number of bolts depends on their height “A” – four bolts for 500 mm high protectors and six for 1,000 mm protectors.



Upright protector. Assembly.

Rail guides. Due to its design and functionality, the compact pallet racking system requires operators to handle mechanical equipment with care in order, on the one hand, to prevent impacts on the racking that could damage its components and compromise its stability and, on the other hand, to achieve good logistics productivity by reducing load access times. This structure contributes to both objectives by acting as a guidance system for load-handling machinery.

The solution consists of a curved element at its front end and a support profile. It is fixed to the floor using anchor bolts. It is positioned at the entrance to the aisles, wrapping around each of the front uprights of the initial racks. It features a series of cut-outs at its base to ensure a perfect fit between the racks, thus guaranteeing minimal intrusion into the aisle whilst meeting the required tolerances.

The components described above are made of high-strength steel, with dimensions appropriate to the system's functional characteristics.

The inclusion of guides in the installation does not require any provision in the initial design, so they can be incorporated at a later stage to ensure compliance with the safety margins established by current regulations.

The following diagram shows the arrangement of the components described:



2.2.9. Fastening elements

Shown below are the different types of fastening elements used to assemble the structures described above.

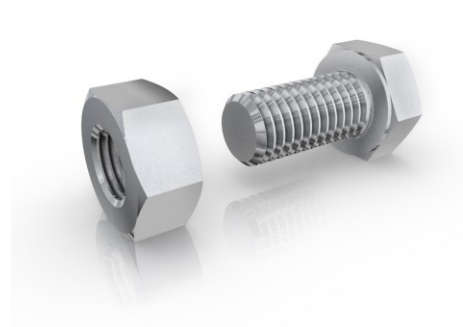

M8x15 nut and bolt



M12x100 anchor bolt



M10x20 nut and bolt



M8x65 / M8x90 / M8x100 / M8x120 nuts and bolts

3. TECHNICAL REPORT

Calculation standards

The compact pallet racking systems are dimensioned in accordance with the design and calculation procedures established in document FEM 10.2.07 The Design of "Drive-in and Drive-Through Racking". The system's design takes into account the tolerances, deformations and clearances specified in standard EN 15620 and the operational requirements described in standard EN 15635.

Static stability and elastic stability verification, and stress and deformation calculations shall be based on mechanical methods and, in general, the theory of elasticity, which occasionally and implicitly admits local states of plastic strain.

Mechanical testing

Application of the standards implies the need to test both the individual components and the assemblies that make up the structure's configuration. These tests have been conducted by Laboratori d'elasticitat i Resistència de Materials (LERMA), at the Barcelona School of Industrial Engineering.

Calculation method and conditions

The structural designs were carried out using finite element analysis by applying second-order calculations and considering geometric nonlinearity. The elastic-plastic behaviour of semi-rigid beam-upright and upright-floor connections was also considered.

In particular, the following concepts were observed:

1. Characteristic actions and analysed actions. Their values have been taken according to specific needs; the values considered derive from the application of the safety coefficient established in standard EN 15512.
2. Permanent actions. The structure's own weight is included in the calculation.
3. Variable actions. The following actions are taken into account:
 - a. Overload due to stored materials.
 - b. Local imperfections. Buckling effects acting on the uprights subject to compression are considered in the calculation by introducing eccentricity.
 - c. Overall imperfection. Horizontal stresses equivalent to 1/200th of the vertical load being stored (according to standard EN 15512) are considered to simulate an out-of-plumb structure and/or load or defects in the material.
 - d. Placement loads. The least favourable placement of the load (highest loading level) is determined according to recommendations in standard EN 15512.
4. Static actions. As an initial assumption, loads are considered static and uniformly distributed over each structural element.
5. Dynamic actions. Dynamic loads are not considered in the structural calculation.
6. Structural safety conditions. A double action is considered: an increase in the amount of load to support by means of a load amplification factor and a decrease in the steel's yield strength by means of a load reduction factor, according to standard EN 15512.
7. The design contemplates the tolerances, deformations and clearances, including interactions with the floor, in accordance with standard EN 15620. The user must ensure maintenance of the appropriate parameters for the installation's safe operation.
8. Seismic, thermal and wind actions are not considered in the system's calculation.

Structure stability

To dimension the pallet racking system correctly, a study was carried out with two calculations corresponding to the two main directions: longitudinal and transverse. These two calculations are independent and cannot be combined.

Longitudinal stability. The longitudinal direction is taken as the direction parallel to the storage system's handling lanes. The connection between the beam connector and the upright provides a level of coupling that guarantees the assembly's longitudinal stability. Additionally, the rear bracings and rails that form a perpendicular connection between frames supplement the system's overall stability.

Transverse stability. The transverse direction is understood to be the direction running perpendicular to the storage system's handling lanes. In the transverse direction, stability derives from the horizontal and diagonal bracings on the frames which consequently behave like trussed girders. The connection between the corbels and rails helps secure the system's transverse stability. All the elements are fixed to the floor, depending on their magnitude, with expansion anchor bolts.

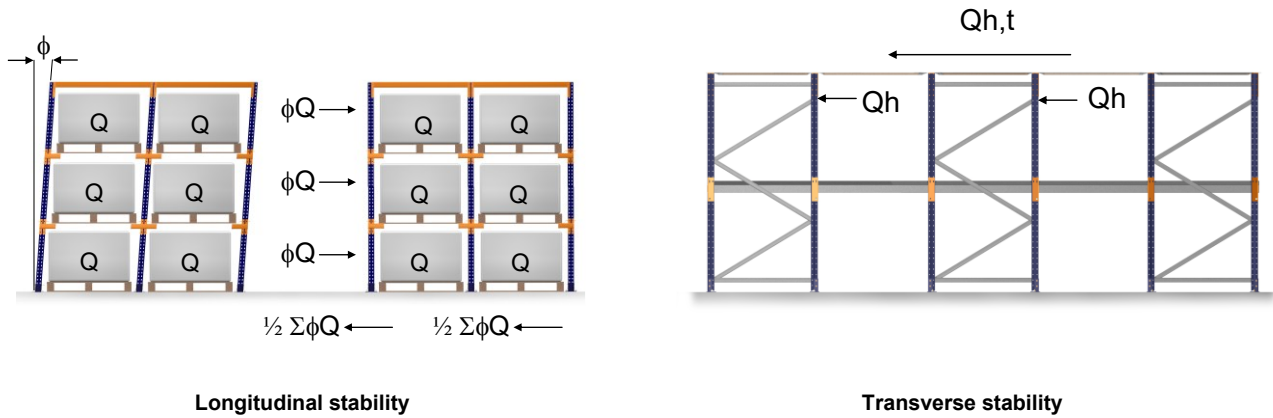

Load assumptions have been defined according to the directives in standard EN 15512 and the aforementioned calculation conditions, while verifying the strains, deformations, and longitudinal and transverse stability in consideration of the permanent and variable loads acting on the structure.

The maximum allowable deformation in beams is set to 1/200th of their length (L/200), in accordance with the indications of standard EN 15620.

Furthermore, the maximum allowable lateral deformation or displacement for the system's uprights is fixed at 1/200th of their height (H/200), according to the same standard.

To a large degree the safety of the racking system will depend on the characteristics, physical condition and evenness of the surface where it is installed. According to European standard EN 15629, it is essential that the floor can support the planned loads and intended use. The customer must ensure the floor meets the requirements for the particular project.

4. LOADING CAPACITIES

Allowable load per frame (kg)

H (mm)	80x63x1.8	100x63x1.8	100x100x1.5	100x100x1.8	100x100x2.0
500	12,470	13,809	16,284	20,439	23,567
1,000	11,943	13,450	15,890	19,941	22,981
1,100	11,796	13,350	15,780	19,801	22,816
1,200	11,634	13,240	15,659	19,648	22,637
1,300	11,459	13,120	15,527	19,482	22,441
1,400	11,269	12,991	15,385	19,303	22,230
1,500	11,066	12,852	15,233	19,110	22,004
1,600	10,848	12,704	15,070	18,904	21,761
1,700	10,616	12,546	14,896	18,685	21,504
1,800	10,371	12,378	14,712	18,453	21,230
1,900	10,111	12,201	14,518	18,207	20,941
2,000	9,837	12,015	14,313	17,948	20,636
2,100	9,549	11,819	14,097	17,675	20,316

2,200	9,248	11,613	13,871	17,390	19,980
2,300	8,932	11,398	13,635	17,091	19,628
2,400	8,602	11,173	13,388	16,779	19,261
2,500	8,252	10,938	13,130	16,453	18,878
3,000	6,328	9,623	11,684	14,626	16,279
4,000	-	-	8,004	9,976	11,259

H = the greater value between the buckling height (distance between the floor and the first level) and the distance between loading levels

Nominal load capacity of frames

The loading capacities for frames presented in the previous table are limited by the distance between levels, the buckling height (measured from the floor to the first level) and the self-weight of the corbels, beams and rails forming the loading levels.

In light of the above, the load-bearing capacities reflected in the previous table must be taken as preliminary and only for reference purposes, given that they will be adjusted according to load and usage limitations which, in any case, must be determined and observed in each project designed by Estanterías Record. In function of these limitations, the result of calculations will take priority, regardless of the nominal load capacity expressed in the above tables.

5. GUARANTEE

Estanterías Record, S.L. guarantees the supplied materials against all manufacturing and assembly defects for a period of 5 YEARS, so long as installation and maintenance services are performed by teams allocated by Estanterías Record.

In the event these circumstances are not met, the period of guarantee will be 1 year and will only cover manufacturing defects in the elements that constitute the storage system.

If assembly is contracted through Estanterías Record, the start date of this guarantee period will be taken as the date when assembly is completed and handover of the storage system is approved. However, if it is assembled by a third party, then the guarantee period will start from the materials delivery date. In either case, the term will elapse regardless of whether or not the storage system is put to use.

This guarantee only extends to the materials supplied for each specific storage system and is only valid under the following circumstances:

- All of Estanterías Record’s instructions contained in the documentation provided to the customer and manuals delivered with the storage system have been followed.
- The storage system has been used in compliance with the original design and intended use, and within the levels of service for which it has been configured pursuant to the specifications in the accepted offer.
- The storage system must be free from any modifications or alterations to the initial assembly, design, function or application, and substitutions or repairs to any components, unless they have been performed with Estanterías Record’s prior written consent.
- Appropriate maintenance and technical inspections, as recommended by Estanterías Record, have been completed.

- Any defects detected by the customer must be reported within a maximum of 24 hours, this includes damage or circumstances that could compromise the storage system's stability; furthermore, the customer must have followed any instructions relating to the matter provided by Esterterías Record.
- The customer has fulfilled all the obligations and responsibilities they must undertake pursuant to the contractual relationship.

During this guarantee period Esterterías Record will repair or replace any components that present serious manufacturing or assembly defects. Normal wear and tear resulting from the system's use and the passage of time are not covered by this guarantee. Repairs will be carried out in the shortest time possible and in accordance with the availability of the necessary personnel.

This guarantee will cover the replacement materials and costs of labour. Withdrawn materials will become the property of Esterterías Record.

The following points are excluded from the guarantee will be invoiced separately:

- The materials and labour used to repair or replace materials damaged as a result of their exposure to aggressive, corrosive, inappropriate or exceptional environments that were not originally planned for. Similarly, the guarantee will not extend to elements or the repair of storage systems located outdoors or subject to the action of atmospheric agents or meteorological phenomena.
- The materials and labour required to resolve damage caused by third parties due to inappropriate use or maintenance, the negligence of warehouse operatives or modifications on the storage system performed without Esterterías Record's consent.
- Interventions to repair damage caused by blows, fire, water, theft, exceptional occurrences or any other acts of God or force majeure.

6. STANDARDISATION AND CERTIFICATIONS

The technical report referred to the reference standards for the calculation and development of storage systems designed by Esterterías Record.

These assemblies are load-bearing metal structures for storing goods with various means of access and logistics management. As stated previously, the assembly of the system's basic components, uprights and beams, using specific connectors, produces three-dimensionally stable structures with intervening aisles that provide access to the storage locations. The main components, while they are only standard pieces for each manufacture, differ from traditional gantry structures, with regards to the standardisation of their design, because the uprights are perforated along their entire length, connections are made with coupling fixtures and their structural elements are generally made from thin-walled, cold-formed sections.

Due to the design characteristics of the structural components, details and types of connection, the EN standards require further technical information in addition to requirements demanded by the Eurocodes. The Eurocodes are universal European regulations drafted under consensus based on the interests of the national administrations with respect to each point and therefore they have a higher status than national regulations; they are designed as a comprehensive and updated framework for structural design and are applicable to storage systems.

The European standards (EN) are developed by CEN technical committees (TCs) whose scope is to establish the EN reference standards for the specification, design, installation methods and accuracy in assembly, while also serving as a safety guide for storage system users.

When this is combined with the need for harmonised standards it explains why the European Materials Handling Federation (FEM) decided to take the initiative from Technical Committee CEN/TC 344, Steel static storage systems, and draft a number of European standards regarding specific types of storage system and

their particular applications; these now exist as European standards (EN) and working group (WG) activities. CEN/TC 344 Steel static storage systems is directly related to CEN/TC 250 Structural Eurocodes, CEN/TC 135 Execution of steel structures and aluminium structures and CEN/TC 149 Power-operated warehouse equipment. *Safety.*

Since the storage system is a load-bearing structure, there are national regulations that require it to be considered “work equipment” and consequently it must comply with European Directive 89/391/EEC, on the introduction of measures to encourage improvements in the safety and health of workers at work.

Lastly, all of these regulations must be applied in accordance with the provisions of standards EN 1990 Basis of structural design, EN 1991 Actions on structures and EN 1993 Design of steel structures.

The numerical values applicable to the partial safety factors provide an acceptable level of certainty, assuming the work is executed in accordance with appropriate quality standards.

Esterias Record strictly fulfils the technical regulations applicable to the design and supporting calculations for our products and services. What is more, our business processes conform to mandatory sectoral, national and international regulations as they comply with applicable guidelines regarding normalisation and legislation.

Furthermore, we systematically apply the directives laid down by ISO 9001:2008 concerning quality control, assurance and management systems to our procedures involving design, development, manufacturing, installation and after-sales service. Our company registration certificate is issued by TÜV International Rheinland, under licence for use number 0.04.03229. TÜV performs regular follow-up audits to ensure the operational performance of our ISO system and verify the aforementioned standard is implemented correctly.

As approved systems must meet the highest technical demands in terms of design, guidelines for testing, calculation, manufacturing, etc., then it culminates in more solid and reliable structures. This contributes to increased safety for the stored goods and above all it is beneficial for the storage system’s end user because it will minimise handling risks in day-to-day warehouse management.

The possession of a storage system developed according to the strictest regulations applicable implies a high degree of security and confidence in the event of demands for accountability or other procedural matters involving insurance companies, financial entities, public bodies, health and safety inspections, etc.

Finally, Esterias Record is a member of the FEM-AEM. The purpose of the FEM-AEM (Spanish Material Handling Association) is to collaborate with national and EU bodies in matters concerning the regulation, improvement and unification of its sector, while also cooperating with partner countries and European manufacturers.

As explained above, Esterias Record is evidently very committed and engaged in terms of meeting the sector’s most stringent requirements so we can offer the market products of the highest quality, safety and guarantee.



Asociación Española
de Manutención



European Materials
Handling Federation



7. AFTER-SALES SERVICES

Storage systems suffer wear and tear through continuous or incorrect use, thereby reducing the functionality and load-bearing capacity for which they were designed, and significantly increasing the risk of accidents. Damaged components or which have received blows, even though the damage may not be visible, can generate dangerous stresses that could even result in its, occasionally, instantaneous and sudden collapse.

The user is responsible for ensuring that their storage system is in good condition and proper working order. To assist in this respect, Estanterías Record can, upon request, provide their customers an inspection and revision service for the installed equipment in order to carry out appropriate preventive or corrective maintenance and minimise these risks.

Additionally, we can: offer our customers advice on the correct use of their storage system regarding safety or what to do in case of accidents; provide them with technical and training manuals covering maintenance; monitor and assess preventive maintenance tasks carried out by the user; perform any corrective interventions that may be required, etc.

Standard EN 15635 concerning “Steel static storage systems. Application and maintenance of storage equipment” establishes the need for storage systems to be inspected at least once a year by an external professional expert.

Given the important consequences that could result from this situation, Estanterías Record recommends that users take note of the above and act diligently in this regard.