



Efficient storage systems

---

## PRODUCT TECHNICAL FILE

---



**CONVENTIONAL PALLET RACKING**  
**PICKING LEVELS**  
**MEZZANINE OVER PALLET RACK**

## CONTENTS

---

	Page
1. SCOPE	2
2. PRODUCT DESCRIPTION	2
2.1. Materials	5
2.1.1. Steels	5
2.1.2. Finishes	6
2.2. Structural elements	7
2.2.1. Frames	7
2.2.2. Bracings	7
2.2.3. Uprights	12
2.2.4. Additional frame components	14
2.2.5. Spacers	15
2.2.6. Beams	15
2.2.7. Loading levels	20
2.2.8. Optional elements	23
2.2.9. Open-plan, walkable overhead loft	27
2.2.10. Fastening elements	33
3. TECHNICAL REPORT	35
4. LOADING CAPACITIES	37
5. GUARANTEE	38
6. STANDARDISATION AND CERTIFICATIONS	39
7. AFTER-SALES SERVICES	41

## 1. SCOPE

Estanterías Record, S.L. designs and manufactures several types of metal racking, shelving and storage systems in compliance with applicable standards. Therefore, we have to document the specifications and characteristics of each product line to create a summarised view of the theoretical parameters and structural and functional elements considered in each particular solution.

This product file aims to provide a general description of the CONVENTIONAL PALLET RACKING system.

It develops an outline of the individual components in the system and the different possibilities to combine them to create the structures which must bear the load of the stored goods. We also describe the materials used to manufacture the components and any other accessories incorporated in the specific, unmodified solution. Finally, it includes a normative justification of the product design calculations and the load-bearing capacities of the product's main elements.

The scope of this report is not exhaustive, but rather it is purely descriptive and aims to provide a broad view of the system's general operation. It is not intended, therefore, to explain all the combinations of uses and components in meticulous technical detail, as this would go beyond the purposes for which it has been conceived; it has been created as an educational, supporting material, so its content should not be considered as a definitive and accurate reference, but rather instructional.

This technical file has been edited strictly in line with the aforementioned objectives. The information it contains is private and must not be subject to distribution, processing, reproduction or transfer of use without the prior express permission of Estanterías Record, S.L. who reserves all of their rights.

The information in this document may be altered without prior notice because of changes related to the products' manufacturing characteristics, because of technical or functional obsolescence of certain elements which may be replaced with others, or because of other adequately justified modifications which have a direct or indirect impact on the content of the text.

## 2. PRODUCT DESCRIPTION

The storage system constitutes an appropriate combination of its structural elements according to the technical and functional parameters for its planned use.

The system's basic components are frames and beams for loading levels. These and some other components are described in more detail below.

Adjoining frames that face each other are connected together using different pairs of beams. Each pair of beams comprises a loading level or surface for the storage of goods.

The volume between two vertically adjacent pairs of beams (a cell) defines the maximum load and the dimensions and quantity of unit loads allowed for the given level.

Each structural unit comprised of two frames and various loading levels is called a module.

Modules are combined to form single or double longitudinal structures called rows. Single rows, or perimeter rows that are usually fixed to the building's walls, are single access storage systems; when two assemblies are braced together they form a double row, i.e., a block of modules with access from both sides.

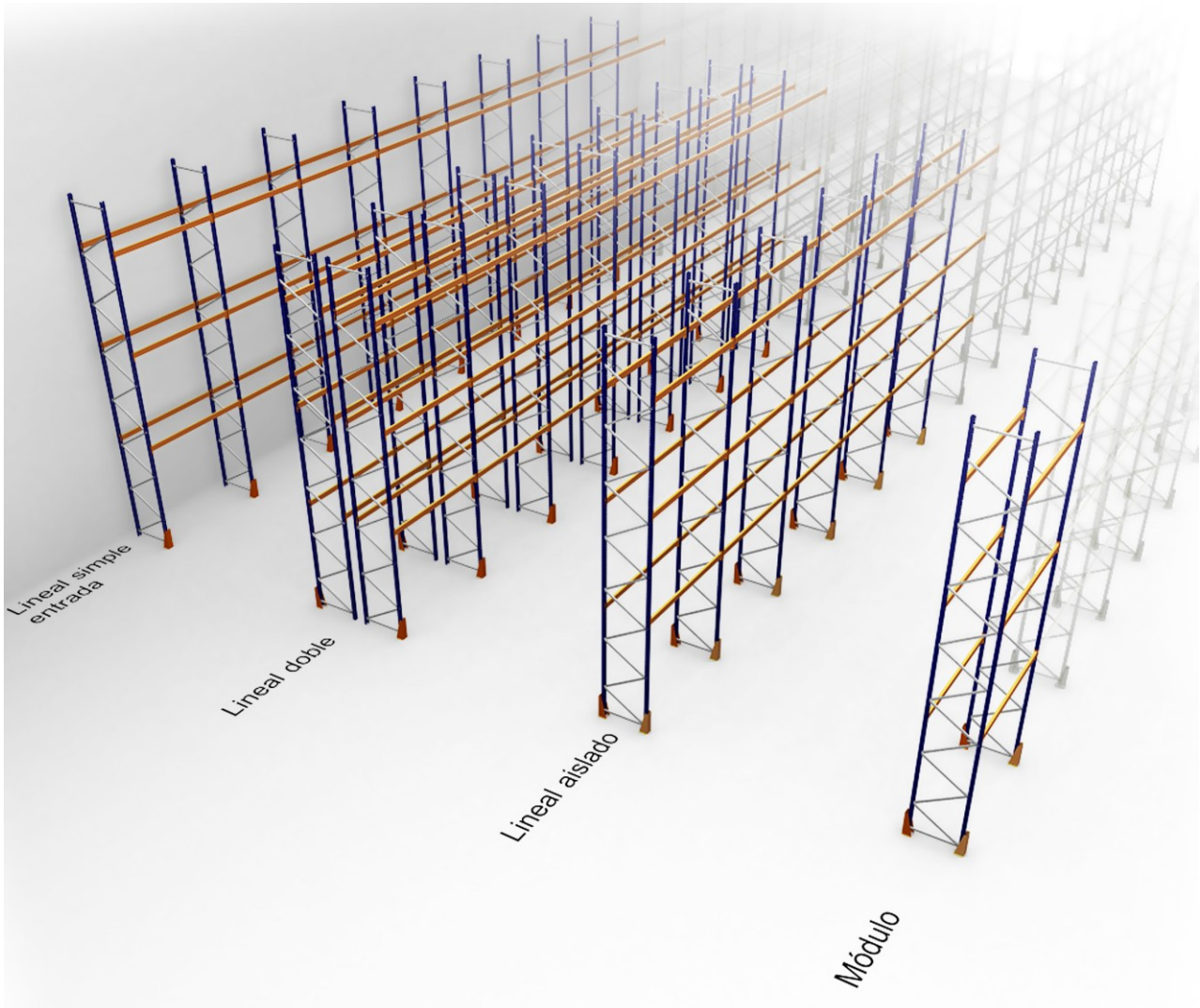

Lines of parallel blocks form intervening aisles whose width is determined by the applicable standards, by the handling equipment available, and by the means of access to and dimensions of the unit loads.

Main advantages:

- Each pallet can be located quickly and accessed directly and immediately.
- Easily adapted as requirements change. The range of accessories and configurations means the storage system can be adapted for use with loads of all weights and volumes.
- Strict control over stored goods. Each space corresponds to a selectively accessible and identifiable pallet; there is no need to move loads to handle the required products.
- Intense flow of stock rotation. Flexibility of use saves time and effort, while also preventing warehouse management errors.
- As the system's structural elements follow an excellent assembly design it can be disassembled and relocated quickly. Alternatively it can be reconfigured or amplified according to new storage needs.

- Optimum use of the vertical space. Loading levels can be adjusted quickly and easily to adapt to different volumes of stored goods.
- Versatility of use. The system's configuration options mean the racks can be used in coordination with any type of handling equipment used in the warehouse (pallet trucks, counterbalanced forklift truck, reach trucks, trilaterals, etc.).
- Damaged components can be replaced easily and immediately.
- A single system can combine palletised loads on the upper levels and manual loading (picking) on lower levels. This maximises the possibility of adapting the system to loads with different formats, weights and volumes.

The user can rest assured that their investment will never become obsolete and that it can evolve and develop in parallel with their business. Once Estanterías Record have completed the appropriate studies, the installed storage system can be reconfigured, expanded or refurbished as and when new circumstances or expansion or relocation requirements arise.

The conventional pallet racking system is designed to optimise stock management and maximise warehouse usage through a controlled investment that is proportional to the benefits and advantages it will bring.

The following diagram provides an example of the design:



Optionally, and in order to increase the storage surface area and capacity, an open-plan, walkable overhead loft accessed using a conveniently located stairway can be installed above the modules that form the basic installation. The open perimeter of this level is protected with guardrails; these can also incorporate access doors, handrails, skirting boards and intermediate guards to act as safety devices. The diagram below shows this configuration:



## 2.1. MATERIALS

Sections are cold-formed and punched from steel strips before they undergo electrostatic painting in a continuous flow, phosphate, anticorrosive coating and oven curing treatments.

The load-bearing capacity of the racks is determined directly by the type and quality of steel used in their construction, which is established by the applicable standard, and by the physical characteristics and behaviour of each configuration in response to elastic instability phenomena associated with the individual elements and the structural systems formed from combinations thereof.

### 2.1.1. Steels

The quality of the steels used to manufacture the different elements varies depending on the structural requirements of the specific solution.

All the pickled steel strips used to manufacture the sections are certified at source.

Depending on each element's end use, nominal values for yield stress,  $f_y$ , range between 235 N/mm<sup>2</sup> and 355 N/mm<sup>2</sup>, in accordance with standard EN 10025.

Values for ultimate tensile strength,  $f_u$ , vary from 360 N/mm<sup>2</sup> to 510 N/mm<sup>2</sup>, as per standard EN 10025.

They are guaranteed to have the following mechanical characteristics:

<b>Property</b>	<b>Value</b>
Elastic modulus	$E = 210000 \text{ N/mm}^2$
Shear modulus	$G = E/2(1+\nu) \text{ N/mm}^2$
Poisson's ratio	$\nu = 0.3$
Coefficient of linear thermal expansion	$\alpha = 12 \times 10^{-6} \text{ }^\circ \text{C}$
Density	$\rho = 7850 \text{ Kg/m}^3$

The system's metal elements are grade A1 (M0), according to certification at source, in compliance with Spanish Royal Decree 2267/2004, dated December 3, which approved the fire safety regulations in industrial premises. Elements with a zinc coating of less than 100  $\mu\text{m}$  have a fire rating of M1, class B-s3,d0, in accordance with standard UNE-EN 13501-1:2007.

### 2.1.2. Finishes

All ungalvanised elements are painted to obtain a surface finish using an automated, double rail, continuous flow process with several treatment stages: cleaning, degreasing, phosphating, anticorrosive coating, pigment spraying and curing. Pieces are degreased before painting by means of phosphate and passivation treatments. A thermosetting epoxy polyester paint is then applied using a robotised electrostatic sprayer and oven cured immediately at 200  $^\circ\text{C}$  for 15 minutes.

This produces a glossy, uniform coating approximately 65  $\mu\text{m}$  thick with a high impact, wear and corrosion resistance, a fire rating of M1, in accordance with standard UNE 23727-90, certified at source, tested according to standards UNE-EN 13823:2002 and UNE-EN ISO 11925-2:2002, and classified in line with UNE-EN 13501-1:2007 B-s2,d0, both certified at source. The coatings' mechanical specifications are presented below:

<b>Property</b>	<b>Standard</b>	<b>Result</b>
Gloss	ISO 2813	84
Adhesion	ISO 2409	GTO
Direct and reverse impact	ISO 6272	70 cm
Cupping	ISO 1520	7 mm
Bend test	ISO 1519	5 mm
MEK	IC-101	100 DF
Salt spray hours		500

Vertical elements are painted blue (RAL 5003) and horizontal ones orange (RAL 2009).

Like the paints, all other auxiliary materials used to manufacture the system's elements are selected according to the specifications and requirements of applicable standards, their production and reception processes are certified, and they are constantly subjected to the tests and inspections established by the quality assurance and management procedures in ISO 9001:2008.

## 2.2. STRUCTURAL ELEMENTS

### 2.2.1. Frames

The frames correspond to the structure's basic vertical elements. Each frame comprises two uprights connected by a series of horizontal and diagonal bracings secured with grade 8.8 DIN 931 M8x65 bolts. The bolts are made from high strength steel and fitted with DIN 985 self-locking safety nuts and Teflon® washers to ensure they do not become loose with use.



Height (mm)	Depth (mm)
2,000	500
2,500	600
3,000	800
3,500	900
4,000	1,000
4,500	1,100
5,000	1,200
5,500	1,300
6,000	1,400
6,500	1,500
7,000	
7,500	
8,000	
8,500	
9,000	
9,500	
10,000	
10,500	
11,000	
11,500	
12,000	

This structure will bear the axial compression load in service conditions and transmit it to the floor. They are also subject to the lateral thrust produced by the mechanical forces acting in the system.

### 2.2.2. Bracings or trusses

Steel sections with a guaranteed minimum grade of DC01, while higher grades, DC03 and DC04, may be used as per standard UNE-EN 10130. All bracings are C-sections with dimensions of 40x28x9.2 mm and 9 mm diameter holes drilled at both ends. Their length depends on the depth of the frame.

The horizontal and diagonal bracings are appropriately triangulated. Intersections between diagonal and horizontal bracings, or those between two diagonal bracings, are fixed to uprights using DIN 931 M8x65 or M8x90 bolts with DIN 985 M8 self-locking nuts.

The following diagram shows the start of the bracing structure.

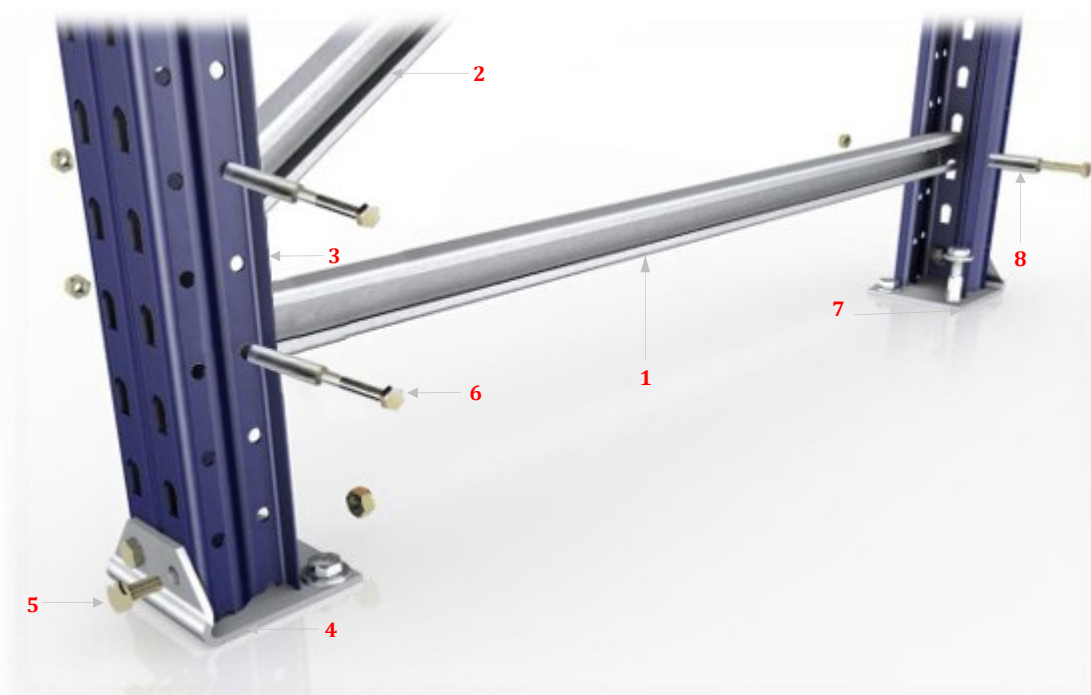

No.	Description
1	Horizontal bracing
2	Diagonal bracing
3	Upright
4	Base plate

No.	Description
5	M10x20 bolt
6	M8x65 / M8x90 bolt (*)
7	Anchor bolt
8	Spacer fitting

(\*) M8x90 metric bolts are only used when the frame is constructed with 100 63 uprights, all other assemblies are secured with M8x65 bolts.

The distance between diagonal bracings is fixed at 550 mm for all frames, which gives a maximum span between trusses of 1,100 mm. The angles between diagonal bracings generally ranges from 20° to 70°.

The free ends of the horizontal and diagonal bracings (where there aren't any nodes) are bolted to the uprights. Spacer fittings are used to prevent any slack between bracings and the upright. These are hollow rectangular parts measuring 14x14 mm and 51 mm long which fill the gap between the bracing and the upright.

The diagram below shows how the components are arranged in the structure explained above, as well as the assembly dimensions and details for each frame height:

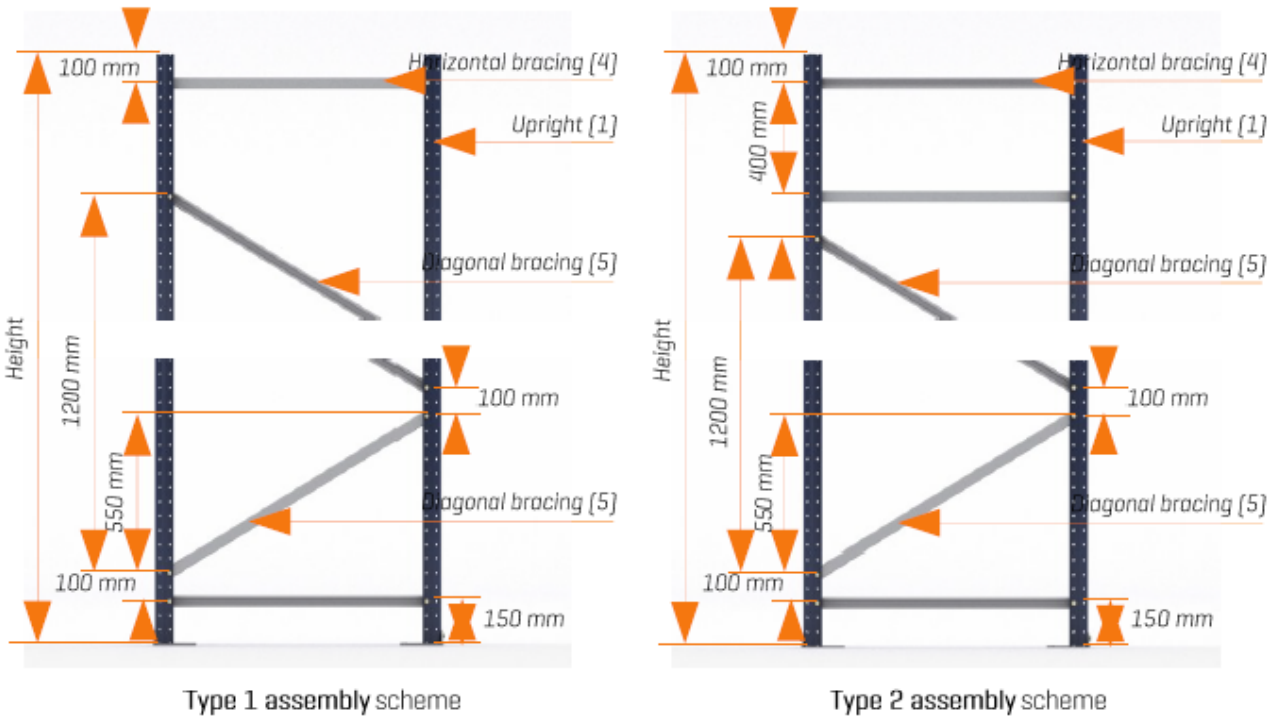

The table below shows the bracing components for each height of frame.

Height (mm)	Uprights Units	Base plates Units	Plate bolt Units	Spacer fittings Units	Horizontal bracings Units	Diagonal bracings Units	Bolts (*) Units
2,000	2	2	4	4	2	3	7
2,500	2	2	4	2	2	4	7
3,000	2	2	4	2	2	5	8
3,500	2	2	4	2	2	6	9
4,000	2	2	4	2	2	7	10
4,500	2	2	4	4	2	7	11
5,000	2	2	4	4	2	8	12
5,500	2	2	4	4	2	9	13
6,000	2	2	4	4	2	10	14
6,500	2	2	4	4	2	11	15
7,000	2	2	4	2	2	12	15
7,500	2	2	4	2	2	13	16
8,000	2	2	4	2	2	14	17
8,500	2	2	4	2	2	15	18
9,000	2	2	4	2	2	16	19
9,500	2	2	4	2	2	17	20
10,000	2	2	4	4	2	17	21
10,500	2	2	4	4	2	18	22
11,000	2	2	4	4	2	19	23
11,500	2	2	4	4	2	20	24
12,000	2	2	4	4	2	21	25

(\*) Length varies depending on the type of strut

The diagrams below show the different types of node and illustrate whether or not spacer fittings need to be fitted.

No.	Description
1	Horizontal bracing
2	Spacer fitting
3	Upright
4	M8x65 / M8x90 bolt (*)

Detailed diagram of bracing elements

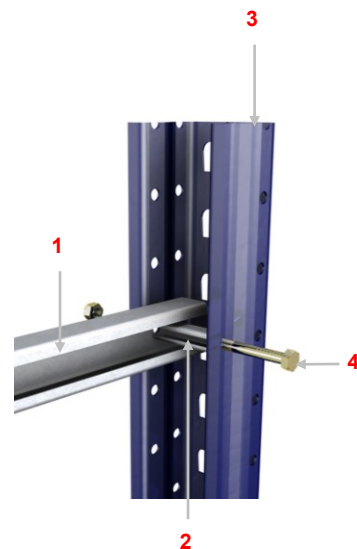

(\*) M8x90 metric bolts are only used when the frame is constructed with 100 63 uprights, all other assemblies are secured with M8x65 bolts.

Dimensions of horizontal and diagonal bracings:

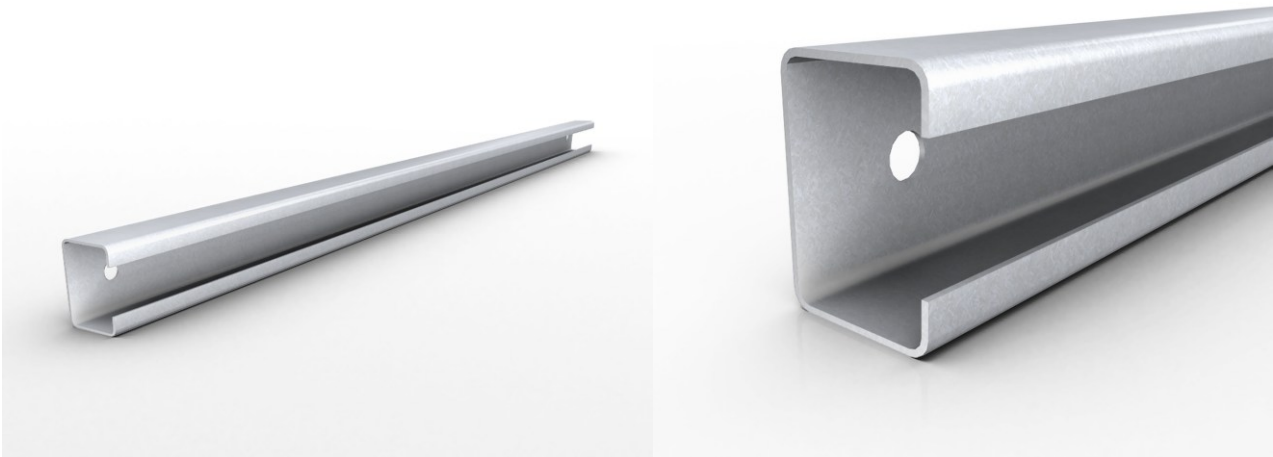
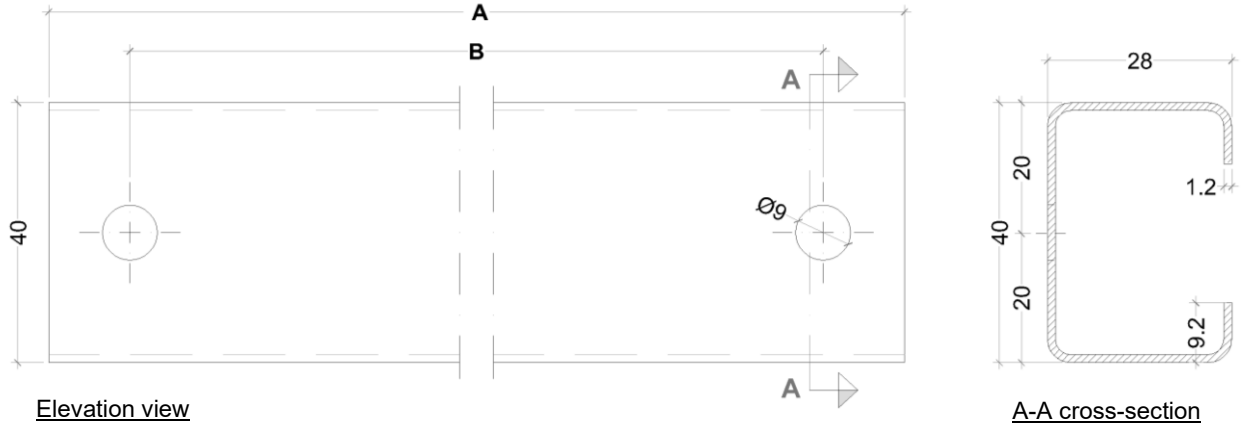

Horizontal/diagonal bracings

Frame depth	Diagonal bracings (mm)			
	Upright 80 63/100 63		Upright 100 100	
	A	B	A	B
500	730	680	693	643
600	793	743	750	700
800	940	890	889	766
900	1,021	791	966	824
1,000	1,105	1,055	1,048	998
1,100	1,191	1,141	1,133	1,083
1,200	1,280	1,230	1,220	1,170
1,300	1,370	1,320	1,309	1,259
1,400	1,462	1,412	1,400	1,350
1,500	1,554	1,504	1,492	1,442

Frame depth	Horizontal bracings (mm)			
	Upright 80 63/100 63		Upright 100 100	
	A	B	A	B
500	450	400	383	333
600	550	500	483	433
800	750	700	683	633
900	850	800	783	733
1,000	950	900	883	833
1,100	1,050	1,000	983	933
1,200	1,150	1,100	1,083	1,033
1,300	1,250	1,200	1,183	1,133
1,400	1,350	1,300	1,283	1,233
1,500	1,450	1,400	1,383	1,333

### 2.2.3. Uprights

Hot-rolled, as per standard EN 100252:2004, and cold-formed S235JR to S355JR grade steel C-sections, with an appropriate thickness for the load they must bear.

They feature two lines of holes, each separated by 50 mm, along their front surface; the connectors for the load-bearing beams slot into these holes. There are also two rows of holes, measuring 9 mm in diameter and again separated by 50 mm, facing each other on both sides of the uprights. These holes are used to attach the bracings.

As detailed above, the holes in the front of the uprights can be used to graduate the loading level every 50 mm.

Each flat element subject to compression is duly stiffened to ensure it performs correctly in case it gets dented. To this end, the uprights have nine longitudinal pleats which confer excellent stiffness against these phenomena; these pleats have been especially designed so that their inertia in function of their width, length and thickness ensures the structure is sufficiently stiffened for the service conditions which it must endure.

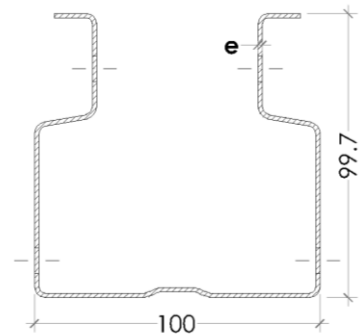
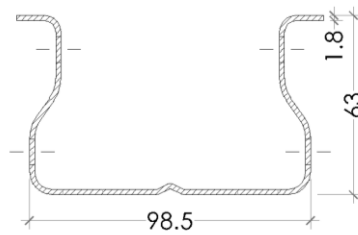
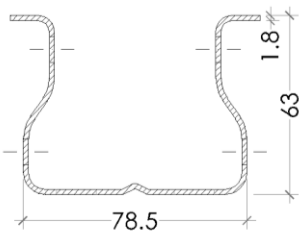
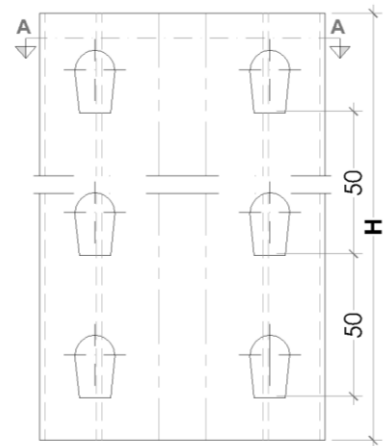
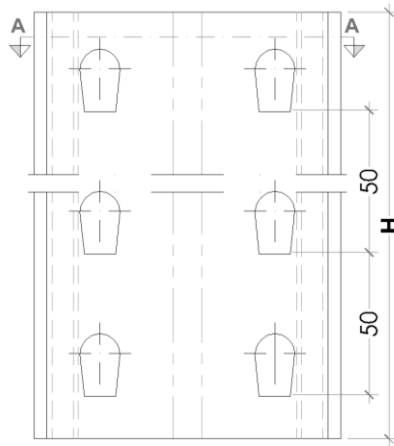
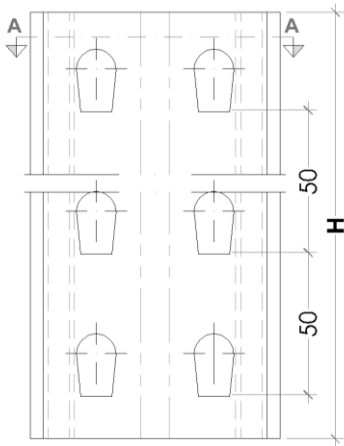

Plan view Upright 80 63

Plan view Upright 100 63

Plan view Upright 100 100  
e = 1.5 / 1.8 / 2.0 mm



**Uprights 80 63, 100 63 and 100 100**

#### 2.2.4. Additional frame components

Each upright is fitted with a metal foot or base plate especially designed to transmit the load to the floor and control any punching shear or settlement phenomena in the underlying concrete. This is also affected by the dimensions and characteristics of the concrete floor slab.



Upright 80 63 with base plate



Upright 100 63 with base plate



Upright 100 100 with base plate

The surface supporting the racking system must always be of sufficient quality and strength to bear the maximum loads for which the system has been designed. Concrete reinforced with a 4 mm diameter metal mesh measuring 150x150 mm, at a minimum thickness of 150 mm, and with an allowable compressive strength of M200 (200 kg/cm<sup>2</sup>), or greater, is acceptable for these loads.

What is more, it must be perfectly levelled to ensure the vertical elements are plumbed correctly. Therefore, the maximum permissible unevenness between any two points of the slab must not exceed  $\pm 10$  mm.

Lastly, and depending on the condition of the concrete floor slab, a levelling plate shall be fitted between the base plate and the floor to correct any unevenness and plumb the frame.



### 2.2.5. Spacers

Frame spacers. These join together double rows of racks and help stiffen the structure against mechanical instability. They are attached to the frame uprights using four M8x15 bolts.

Wall spacers. These are used to secure single rows of racks against a wall. They consist of a frame space and a wall bracket, which are assembled using M8x15 bolts and fixed to the wall with wall plugs and lag screws. Their use is optional and they contribute to the system's overall stability.

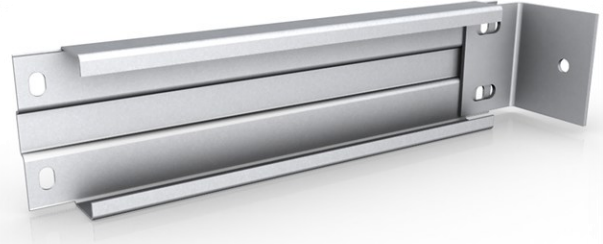

Frame space

Wall spacer

Nominal length of frame/wall spacers ND (mm)

100	400	700	1,000	1,300
150	450	750	1,050	1,350
200	500	800	1,100	1,400
250	550	850	1,150	1,450
300	600	900	1,200	1,500
350	650	950	1,250	

### 2.2.6. Beams

Beams are the horizontal elements that support the load and, together with the frames, correspond to the basic structural components of the conventional pallet racking storage system.

Depending on the product to be stored and the means of accessing the rack for handling purposes, there are different types of beam available for the system's basic modules:

Conventional beams. These are made up of two C-sections assembled to form a tubular structure. Connectors are attached to both ends using high-strength welding so that the beams can slot onto the frames. This element is available in different cross-sections depending on the uniformly distributed weight each pair of beams forming a loading level must bear.

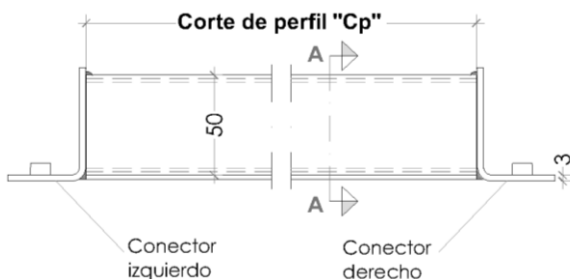

Plan view 80, 100, 120, 140x50 beams

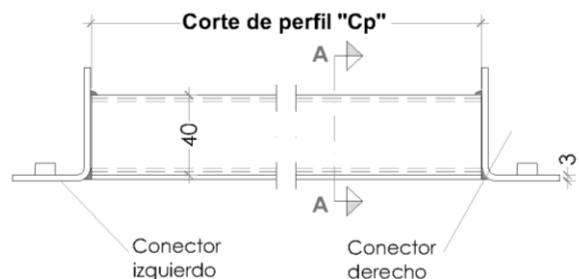

Plan view 100, 120x40 beams

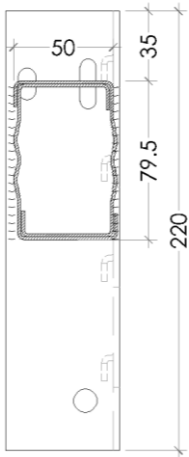

Cross-section A-A  
80x50 beam

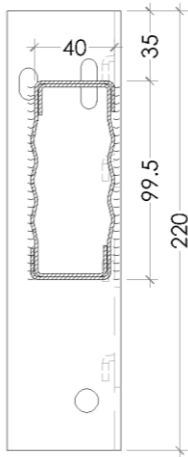

Cross-section A-A  
100x40 beam

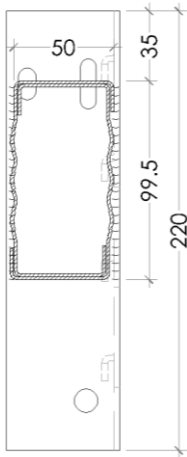

Cross-section A-A  
100x50 beam

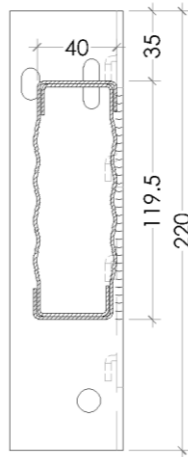

Cross-section A-A  
120x40 beam

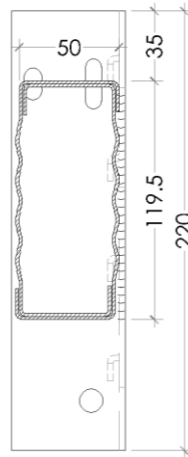

Cross-section A-A  
120x50 beam

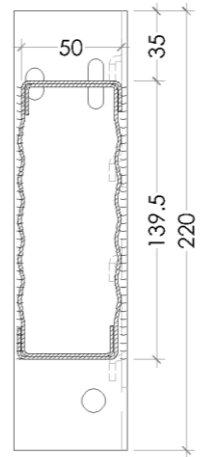

Cross-section A-A  
140x50 beam



80 section



100 section



120 section



140 section

Overhead loft beams. These are made up of two C-sections assembled to form a tubular structure. Connectors are attached to both ends using high-strength welding so that the beams can slot onto the frames. They are also available in different cross-sections according to loading requirements. These are used when the tops of the beams and connectors must have the same height and lie flush with each other.

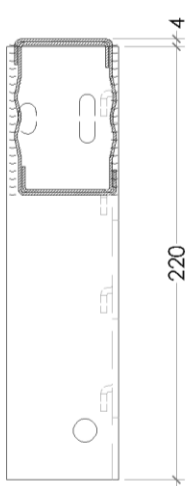

Cross-section A-A  
**80x50 beam**

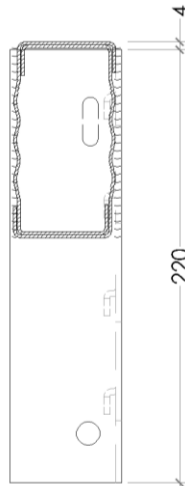

Cross-section A-A  
**100x50 beam**

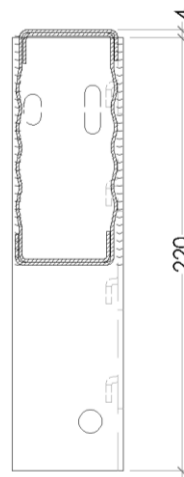

Cross-section A-A  
**120x50 beam**

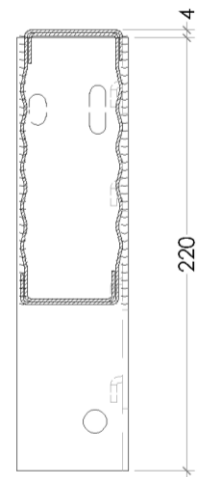

Cross-section A-A  
**140x50 beam**

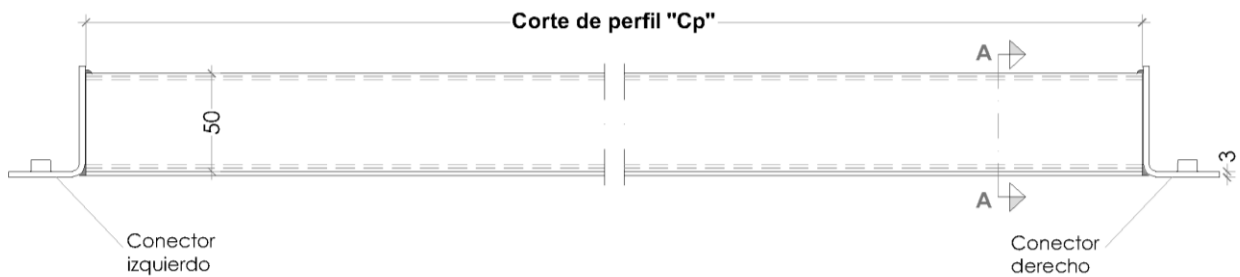

Plan view



80 section



100 section



120 section



140 section

Z80 beams. These consist of one Z-section with two connectors welded onto both ends so they can slot onto frame uprights. They are used in conventional configurations of this type of storage system whose design includes the installation of an open-plan surface for the direct storage of goods. In this case unit loads will be managed with manual handling equipment. This element is available in different cross-sections depending on the uniformly distributed weight each pair of beams in a loading level must bear. These beams have a maximum nominal length of 2700 mm.

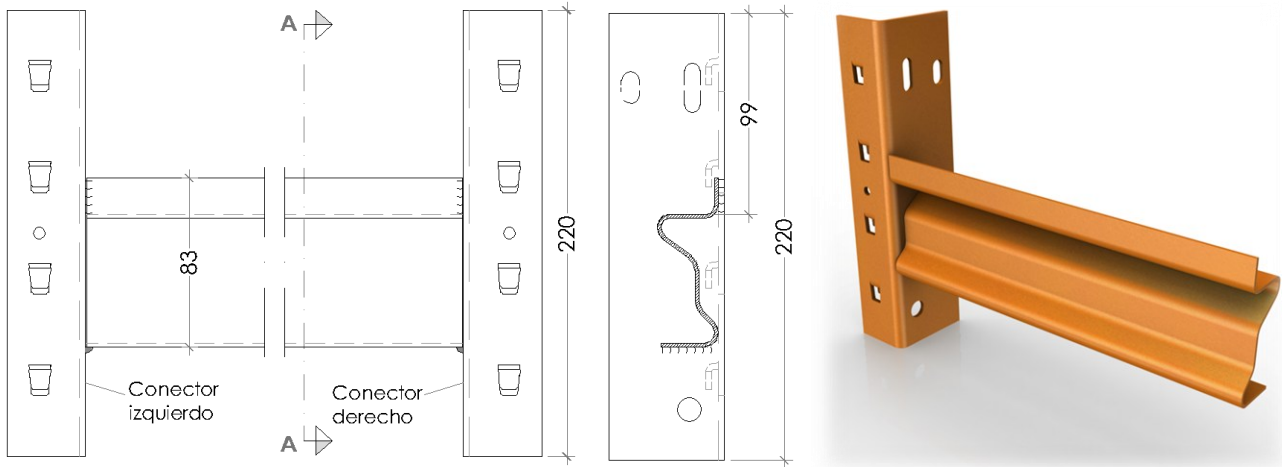

Elevation view

A-A cross-section

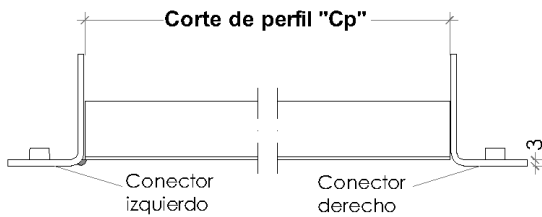

Plan view

**Beam lengths (mm)**

<b>Nominal dimension (ND)</b>	<b>Section length (Cp)</b>
1,350	1,350
1,900	1,903
2,300	2,303
2,710	2,703
3,350	3,350
3,650	3,650
3,950	3,950

Essentially, the beams are subject to bending and lateral-torsional buckling forces. Each flat element is duly stiffened at each point subject to compression to ensure it performs correctly in case it gets dented. Otherwise, the element could fail under shear loads, bending moments or a combination of the two. The tubular beams incorporate longitudinal ribs along their full length to confer greater stiffness and strength.

Each beam accepts a maximum deformation equal to 1/200th of its total length, as per standard EN 15620.

The beams are fitted onto the frame by means of beam connectors. These parts transmit the load acting on the beam to the frame. Connectors are cold-formed L-shaped sections measuring 29x28x3 mm; they are attached to the beam by robotic welding, producing a very stiff connection that meets the most demanding tensile strength safety coefficients for the intended function.



They attach to the frame by means of four 11-mm hooks projecting from the connector and which fit into the corresponding holes in the uprights. This type of connection is specifically designed to transmit the thrusts from the service load correctly, thus minimising strain in the system and self-centring compressive forces to prevent risks associated with shearing stress.

After fitting the connectors to the frame they are locked with safety pins to ensure beams cannot suffer any vertical movements. These pins do not, therefore, fulfil a load-bearing purpose but rather act as a locking device to prevent movements due to external thrusts, primarily when handling goods in a cell.

This assembly system provides a great deal of versatility of use, minimises assembly/disassembly times, and confers great longitudinal stability and strength to the overall structure.

### 2.2.7. Loading levels

When load units are accessed manually, the beams must support the surface where the goods will be stored. There are two options in this regard depending on the weight of the load.

Z80 picking level. Consisting of two Z80 beams, this system is used when the stored goods are handled manually and the level does not have to support heavy loads. With respect to the loading level surface, there are basically two options:

**Metal panels:** These are purpose-designed, galvanised metal panels positioned perpendicularly between two beams. They have matched tongue and groove tabs along the sides so that each group of panels on a level forms a continuous surface, improving their performance and increasing their load capacity. This system is recommended over the one described below because it presents some clear advantages: there is no need for support elements as the actual panels ensure the beams are not subject to lateral-torsional buckling; they are handled with great ease, comfort and flexibility; their metal construction means they are not susceptible to the effects of time or contact with moisture that normally affect fibreboard; greater resistance to scratches, impacts, etc.; increase the overall system's load-bearing capacity given that the metal panels weigh much less than a wooden surface. They are available in lengths of 400, 500, 600, 700, 800, 900 and 1,000 mm, and widths of 100 and 200 mm.

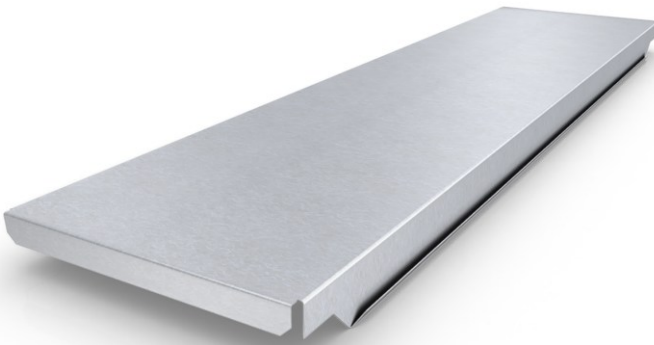

**Galvanised metal panel**

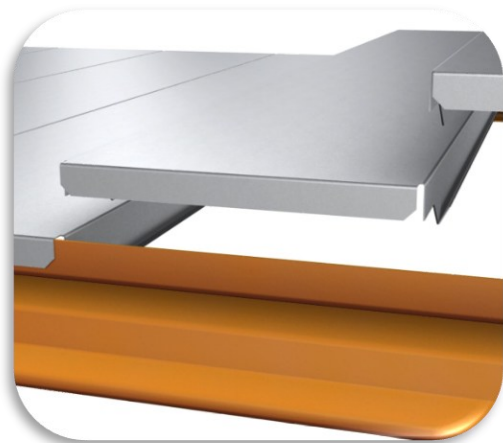

**Positioning on Z beams**

**Fibreboards with supports.** These are boards dimensioned to sit in the grooves found on the Z beams, thus creating a loading surface. As the beams are subject to lateral-torsional buckling due to the load's compressive force, the board could break or dislodge from its seating, causing the stored goods to fall. To avoid this problem, and also to prevent the board itself from buckling, a sufficient number of supports must be installed to control these phenomena. The board supports connect to both beams; this stiffens the structure and, thanks to their robust properties, helps increase the storage system's load-bearing capacity.

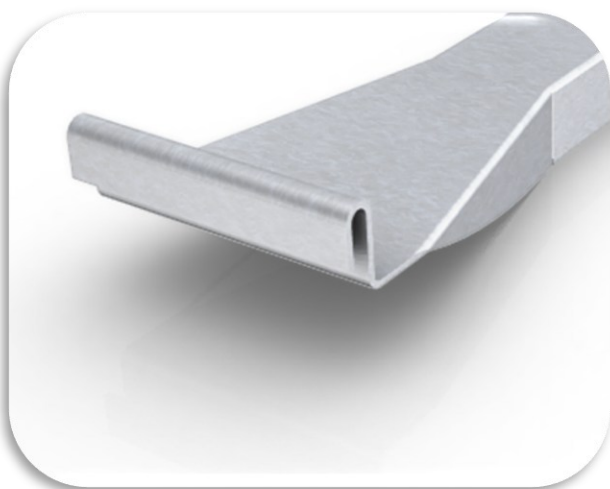

**Board support for Z beams**

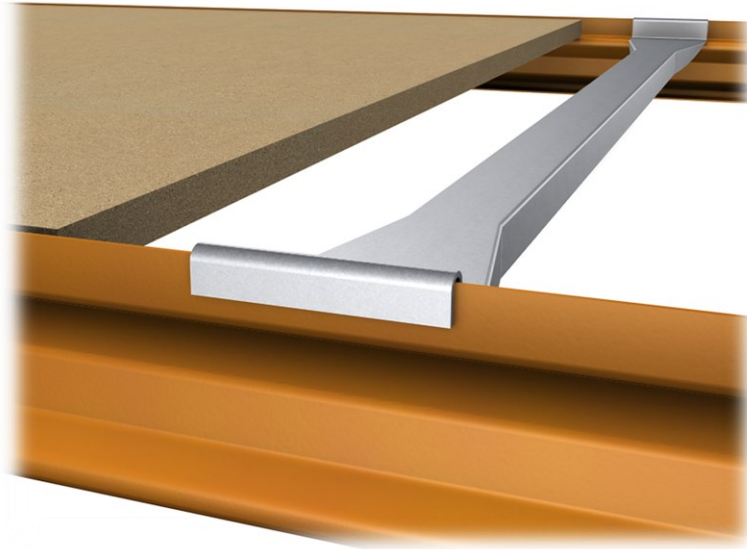

**Z80 picking level with supports and fibreboard**

Conventional 80 picking level. Consisting of two conventional beams, this system is used when the stored goods are handled either manually or using handling equipment and the level does not have to support heavy loads. With respect to the loading level surface, the first option is generally fibreboards. To ensure beams do not succumb to lateral-torsional buckling, and also to prevent the board itself from buckling, a sufficient number of supports must be installed to control these phenomena. The board supports connect to both beams; this stiffens the structure and, thanks to their robust properties, helps increase the storage system's load-bearing capacity.

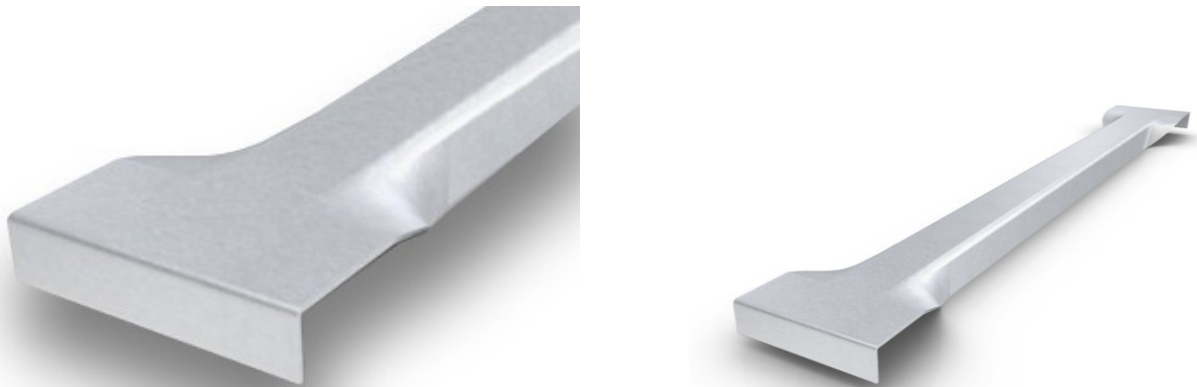

**Board support for conventional beams**

Both types of support are available in lengths of 400 to 1,200 mm, at 100 mm increments.

Additionally, in the case of conventional picking levels board retainers designed to prevent boards from dislodging while handling goods are installed. Normally, four retainers are fitted for each board.

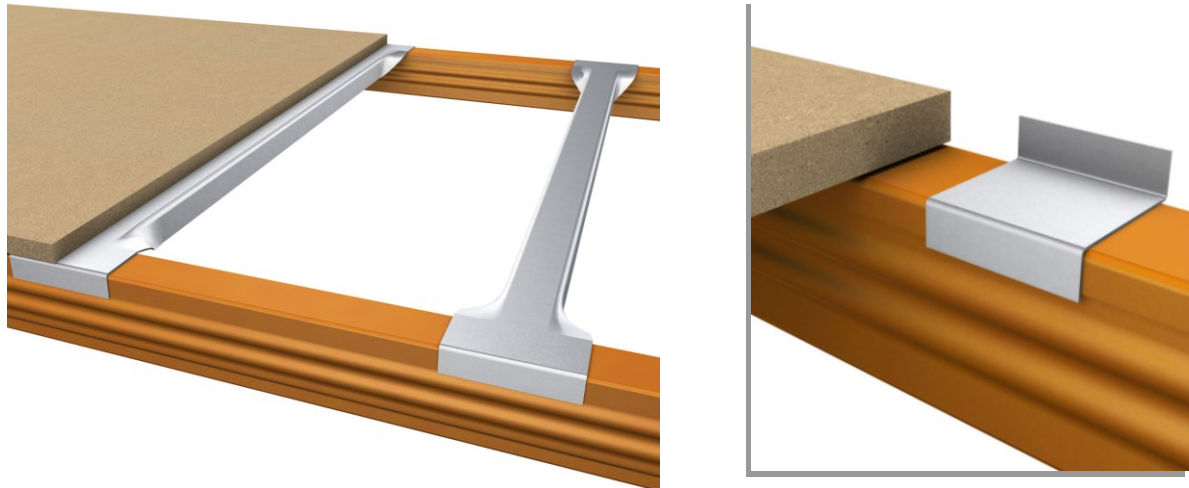

Conventional picking level with supports and retainer

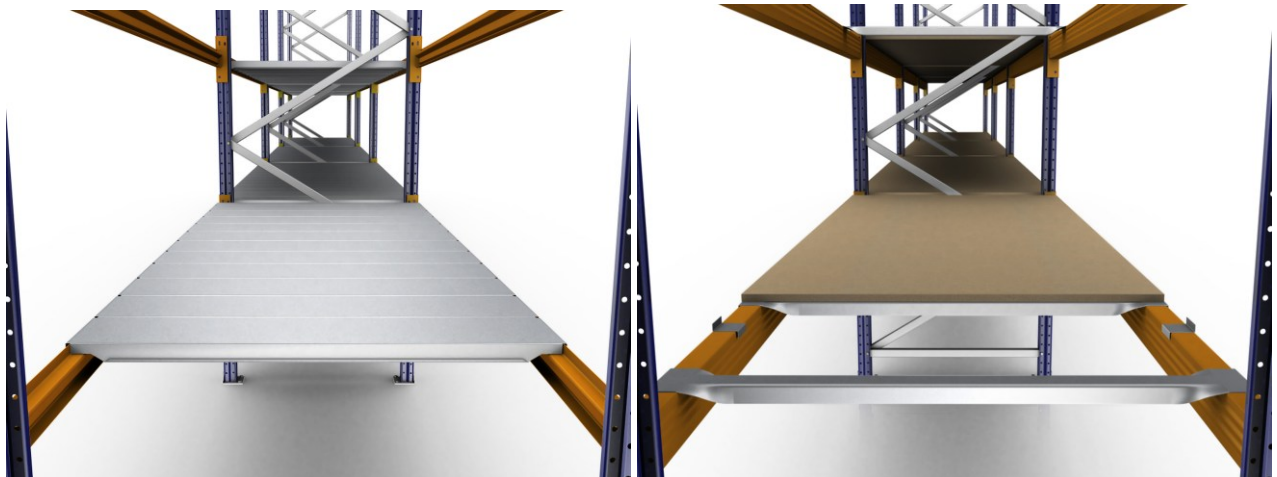

Z80 picking level with metal panels

Conventional 80 picking level

### 2.2.8. Optional elements

The racking system for palletised loads features a wide range of accessories and elements specifically designed for integration into the model described above and to cover diverse requirements depending on the specific conditions of use. Some of these elements are described below:

Pallet stop beams. These consist of two C-sections assembled to form a tubular structure with flat plates attached to both ends using high-strength welding. They are connected to the frames using M8x15 bolts. They act as a stop at the back of the loading level and help guide load positioning during handling. The length of pallet stops matches the length of conventional beams.

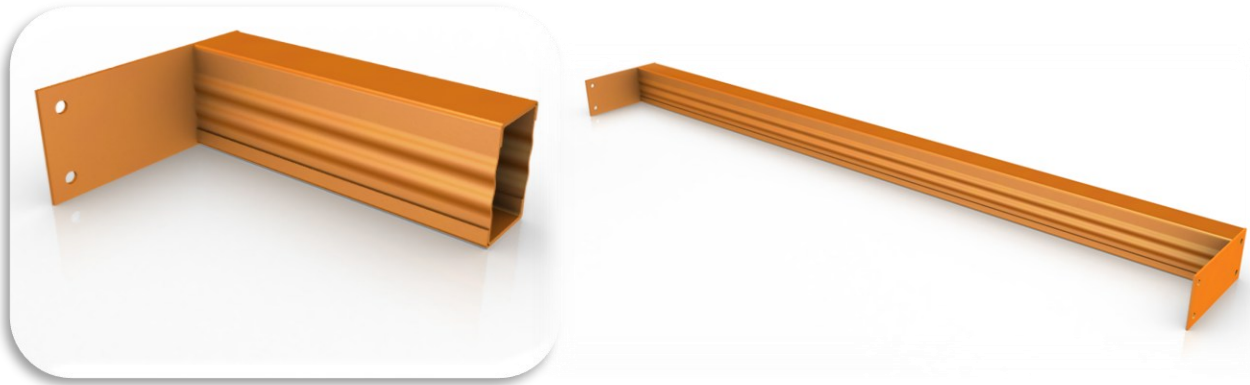

Pallet stop beam

Upright protectors. These are designed according to the dimensions of the different uprights and to protect them from being struck accidentally by work equipment. They are positioned around the base of uprights and are fixed to the floor using four or six anchor bolts, depending on their height. Each protector is made from 3 mm DC01 grade sheet metal.



Protector H = 1,000/500 mm. Positioning

Full protection is installed at the ends of single and double rows, or wherever the ends of frames are exposed to potential impacts from handling equipment. This system consists of one or two (depending on the height of the protectors) cold-rolled steel U-sections running between a pair of upright protectors, all of which are connected by means of M10x20 bolts. This creates a high-strength means of protection from impacts due to forklift trucks.

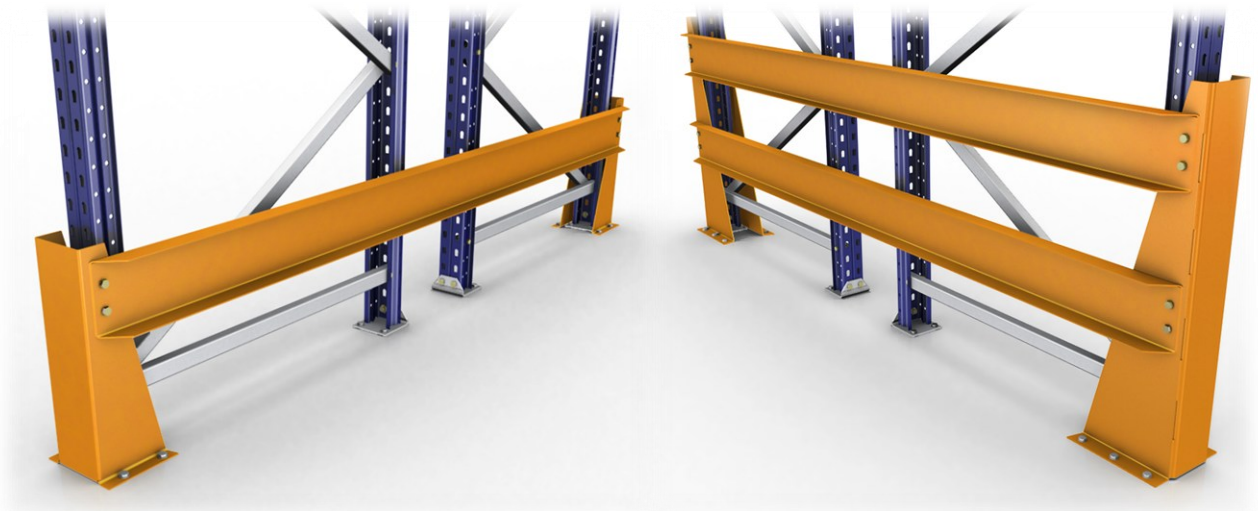

Full protection using one or two sections

Pallet supports. These consist of two C-sections assembled to form a tubular structure with coupling fixtures attached to both ends using high-strength welding. They are fitted onto conventional beams and support load units with variable dimensions, thus providing greater flexibility in how pallets are distributed across the loading level.

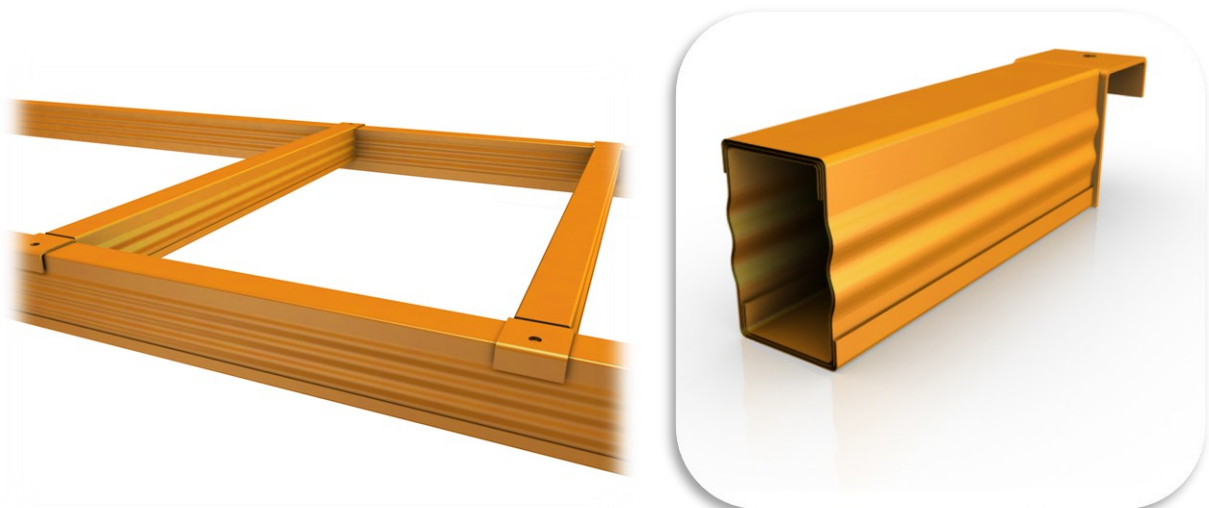

Pallet supports. Positioning and cross-section

Raised pallet supports. Formed from commercial 100x40x3 sections, with two L-shaped guides attached to the ends using high-strength welding and two plates to close the open ends of the sections. These are placed on conventional beams and are used to support non-palletised goods that must be separated from the beams so they can be handled with mechanical equipment.

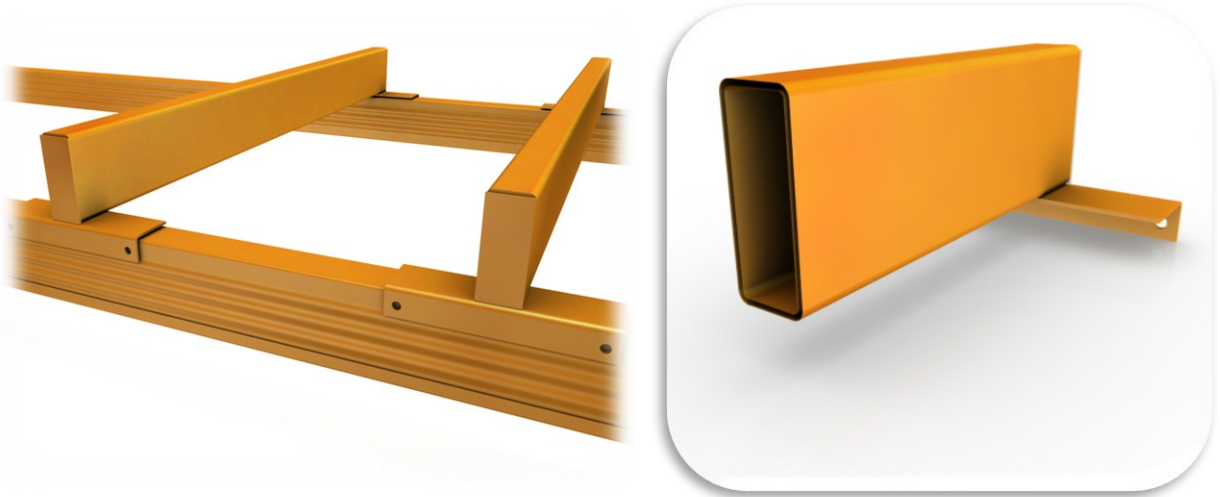

**Raised pallet supports. Positioning and cross-section**

Pallet and raised pallet supports are manufactured in lengths of 600 to 1,200 mm, at 100 mm increments.

Drum cradles. Formed from 3 mm thick folded metal sheets. These are placed on and attached to conventional beams using two M8x65 bolts. They are designed to store drums or other goods with a similar format.

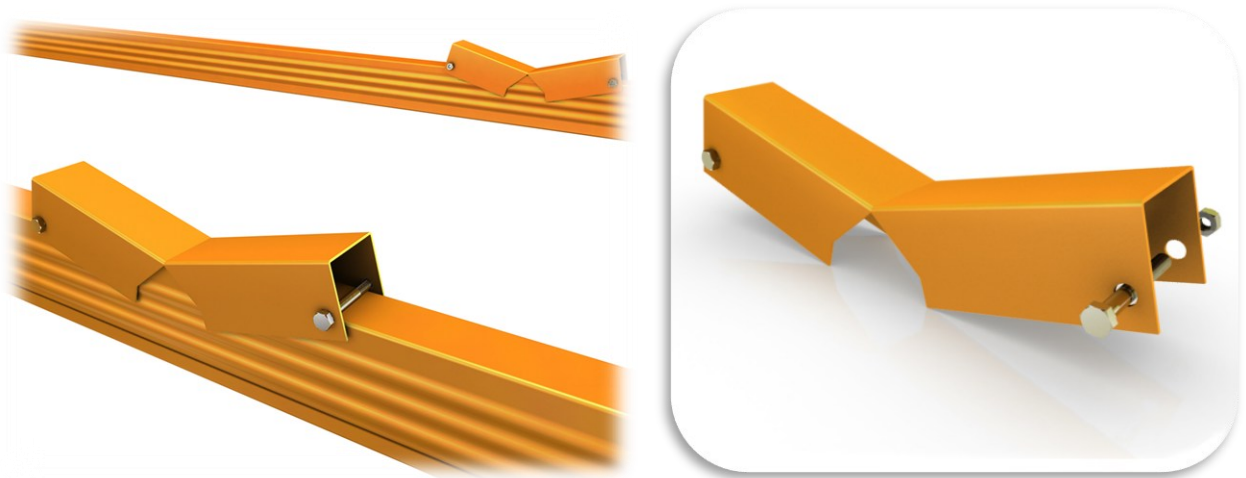

**Drum cradles. Positioning and close-up view**

### 2.2.9. Open-plan, walkable overhead loft

Taking the structure of a conventional pallet racking system as a basis, this storage solution creates an overhead level with an open-plan, walkable surface and characteristics suited to the intended end use. Open perimeter areas are protected with safety guardrails and lofts can be accessed using conveniently located stairways.



Conventional pallet racking with overhead loft

### Support structure

Joists, which are sections that directly support the elements forming the floor's surface, are placed on top of the overhead loft beams, see section 2.2.6. Beams.

The joists are 1.5 mm thick metal sheets folded into a C shape and sections of 80, 100, 120 and 140 mm can be selected according to load requirements.

They may be formed from single or double C-sections depending on the loads and width of the underlying aisles. There are available in lengths of 4,000, 5,000 and 6,000 mm.

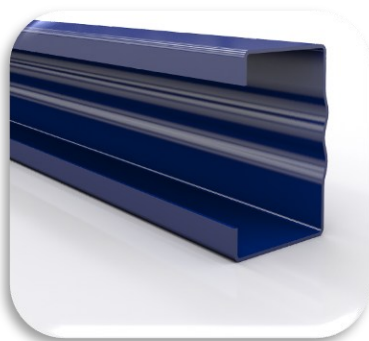

Single joist

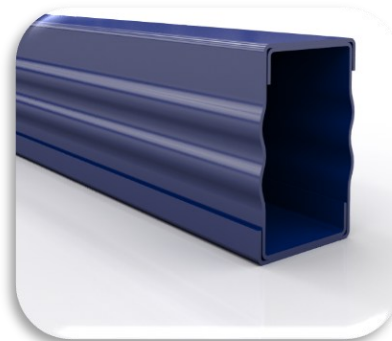

Double joist



**Joists layout**

They are laid perpendicularly on top of overhead loft beams with the necessary spacing to ensure sufficient loading capacity and to support the loft's floor.

Joists are secured to the beams using brackets and self-tapping screws, as shown in the following diagram.

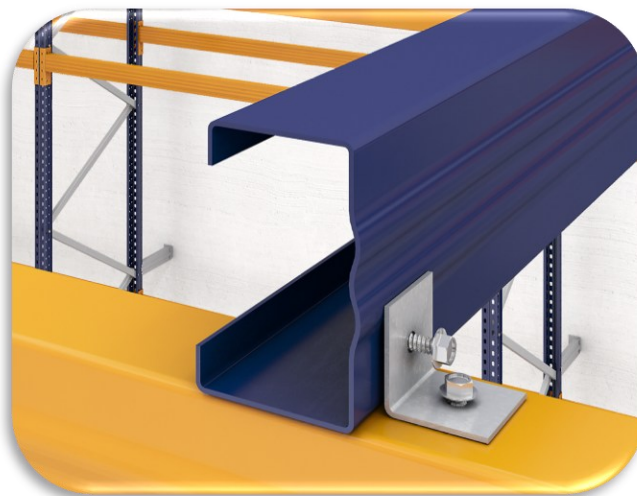

**Joist Attached using a bracket**

### Floor decking

Metal or fibreboard decking, depending on the intended use and load requirements, are installed to create the walkable surface for workers and goods storage.

The decking materials are supported by the joists structure and positioned so that they join together exactly in the middle of the joists to guarantee strong support.

Decking is assembled with the appropriate fixtures and fastenings so that it is secured correctly and to guarantee the stability and safety of the overall structure.

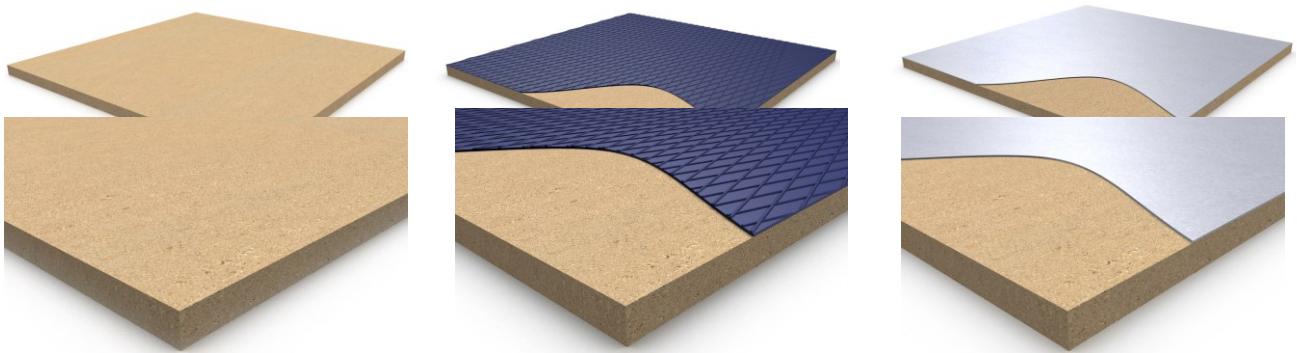

Fibre/melamine/medium-density board  
smooth galv. plate 1.5 mm

Fibreboard and 3–5 mm tread plate

Fibreboard and 1.5 mm

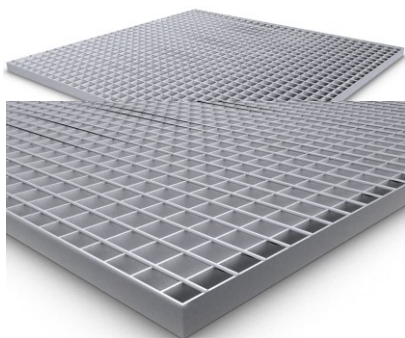

Bar grating



Coarse stamped floorboards

In each case the type of decking is selected according to the storage solution's technical specifications, the intended use and the functional characteristics of the loads and handling equipment used.

Similarly, the fastening method used for each loft ensures the deck is fully immobilised and the parts fit together perfectly to produce a very neat finish.

The diagram below shows the layout of the decking over the joist structure described in the previous section.



Depending on the type of decking used, the exposed sides of the floor and the supporting structure are covered with board joints and/or joist covering sheets, both are secured with 4.8x25 mm sheet metal round head screws.

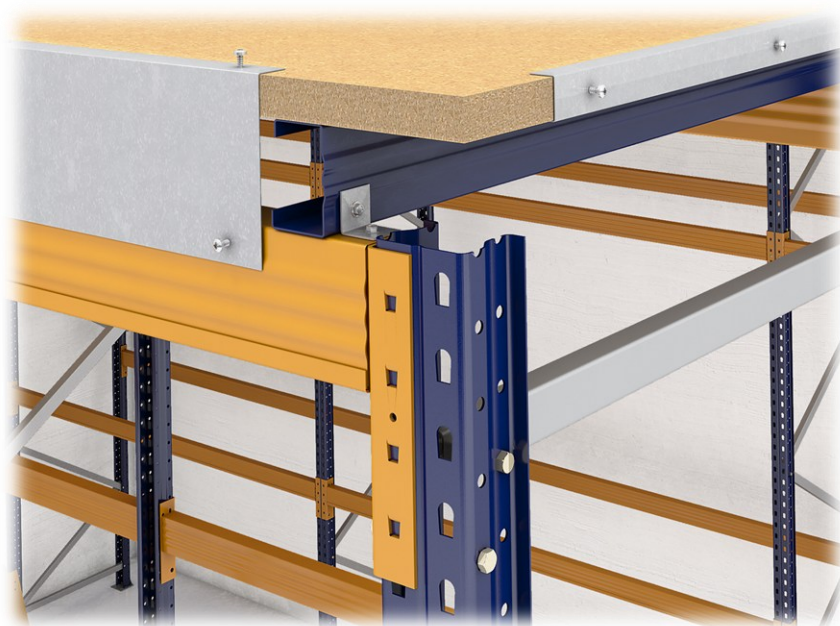

**Joist covering sheets and board joints. Positioning**

## Guardrail

For employee safety, open areas and openings for stairways are equipped with guardrails.

Guardrails are comprised of loft guardrail uprights, handrails, skirting boards and 20 mm diameter protective railings running through the uprights, plus appropriate finishing elements.



Safety guardrail and close-up of finishing elements

Loft guardrail uprights have a flat support base which is secured with two sheet metal screws when they are positioned over a joist or with two M8x45 bolts and a counter plate on the lower surface of the decking when they do not coincide with a joist.

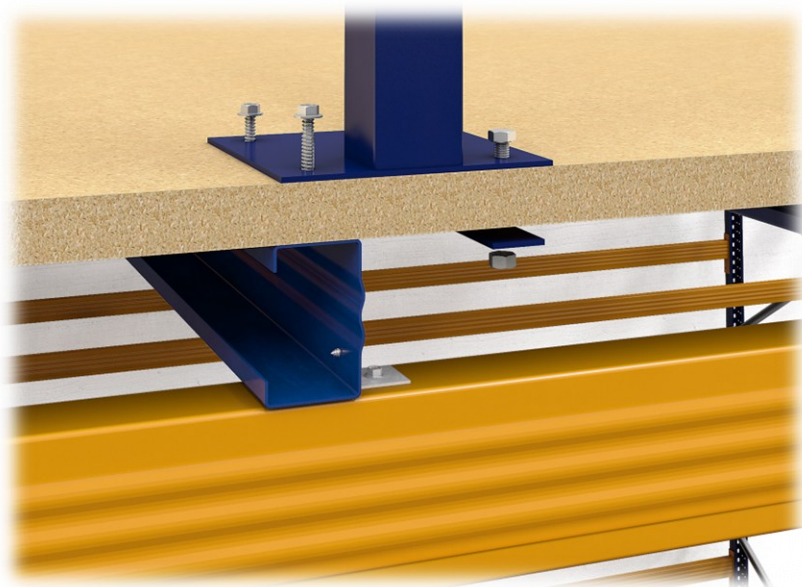

Guardrail upright. Both fastening methods are shown

Opening sections can be incorporated into the safety guardrails along the loft's open sides to act as service doors, thus improving access to the storage surface and facilitating goods handling operations.

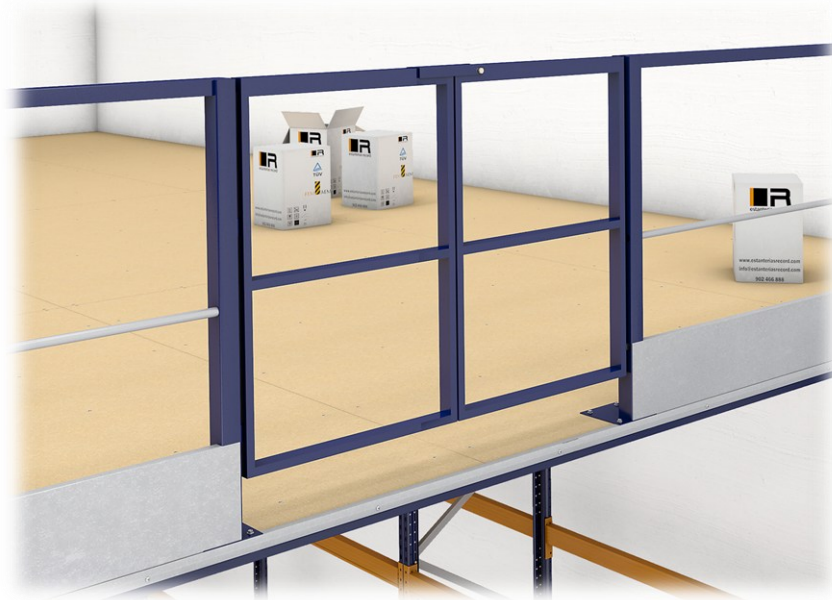

Hinged door in loft guardrail

### Stairways

Overhead storage spaces are connected to the ground level using stairways that provide a safe means of access. Stairways are conveniently located for rapid, comfortable transit without reducing the structure's load-bearing capacity.



The demountable stairways are comprised of two stringers, made from cold-rolled steel U-sections, to which the treads and handrails are bolted. Handrails run along the top of the handrail uprights, while there is a 20 mm diameter protective railing running through these uprights. Stairway structures also feature appropriate finishing elements.

The treads are made from galvanised sheet metal and have round bumps stamped on their upper surface to improve grip.

### 2.2.10. Fastening elements

Shown below are the different types of fastening elements used to assemble the structures described above.



Safety pin

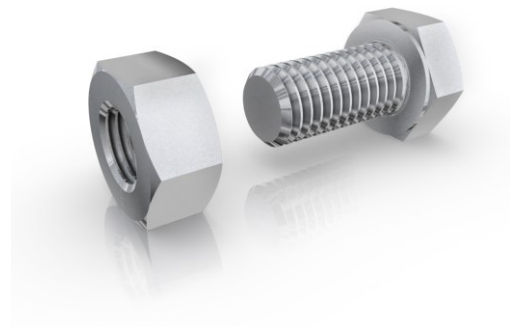

M8x15 nut and bolt



M10x20 nut and bolt



M8x65 nut and bolt



**M12x100 anchor bolt**

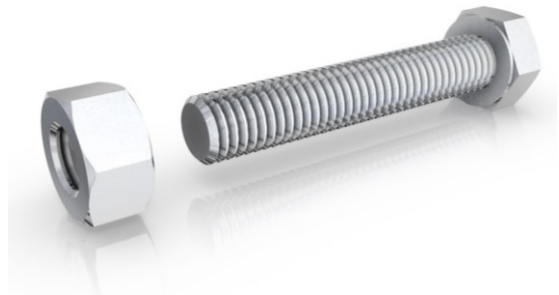

**M8x45 nut and bolt**

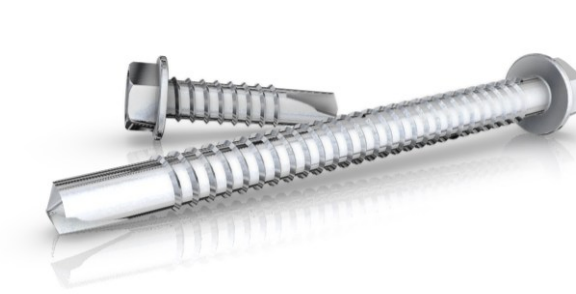

**4.8x25 / 6.3x60 sheet metal screws**



**5.5x60 self-tapping screw**

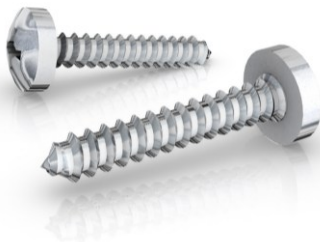

**4.8x25 sheet metal round head screw**

### 3. TECHNICAL REPORT

#### Calculation standards

The conventional pallet racking systems are dimensioned in accordance with the design and calculation procedures established in standard EN 15512, "Steel static storage systems. Adjustable pallet racking systems. Principles for structural design", which in turn conform to standards EN 1990, EN 1993-1-1 and EN 1993-1-3. The system's design takes into account the tolerances, deformations and clearances specified in standard EN 15620 and the operational requirements described in standard EN 15635.

Static stability and elastic stability verification, and stress and deformation calculations shall be based on mechanical methods and, in general, the theory of elasticity, which occasionally and implicitly admits local states of plastic strain.

#### Mechanical testing

Application of the standards implies the need to test both the individual components and the assemblies that make up the structure's configuration. These tests have been conducted by Laboratori d'elasticitat i Resistència de Materials (LERMA), at the Barcelona School of Industrial Engineering.

#### Calculation method and conditions

The structural designs were carried out using finite element analysis by applying second-order calculations and considering geometric nonlinearity. The elastic-plastic behaviour of semi-rigid beam-upright and upright-floor connections was also considered.

In particular, the following concepts were observed:

1. Characteristic actions and analysed actions. Their values have been taken according to specific needs; the values considered derive from the application of the safety coefficient established in standard EN 15512.
2. Permanent actions. The structure's own weight is included in the calculation.
3. Variable actions. The following actions are taken into account:
  - a. Overload due to stored materials.
  - b. Local imperfections. Buckling effects acting on the uprights subject to compression are considered in the calculation by introducing eccentricity.
  - c. Overall imperfection. Horizontal stresses equivalent to 1/200th of the vertical load being stored (according to standard EN 15512) are considered to simulate an out-of-plumb structure and/or load or defects in the material.
  - d. Placement loads. The least favourable placement of the load (highest loading level) is determined according to recommendations in standard EN 15512.
4. Static actions. As an initial assumption, loads are considered static and uniformly distributed over each structural element.
5. Dynamic actions. Dynamic loads are not considered in the structural calculation.
6. Structural safety conditions. A double action is considered: an increase in the amount of load to support by means of a load amplification factor and a decrease in the steel's yield strength by means of a load reduction factor, according to standard EN 15512.

7. The design contemplates the tolerances, deformations and clearances, including interactions with the floor, in accordance with standard EN 15620. The user must ensure maintenance of the appropriate parameters for the installation's safe operation.
8. Seismic, thermal and wind actions are not considered in the system's calculation.

### Structure stability

To dimension the pallet racking system correctly, a study was carried out with two calculations corresponding to the two main directions: longitudinal and transverse. These two calculations are independent and cannot be combined.

Longitudinal stability. The longitudinal direction is taken as the direction parallel to the storage system's aisles. The connection between the beam connector and the upright provides a level of coupling that guarantees the assembly's longitudinal stability.

Transverse stability. The transverse direction is understood to be the direction running perpendicular to the storage system's aisles. In the transverse direction, stability derives from the horizontal and diagonal bracings on the frames which consequently behave like trussed girders. All the elements are fixed to the floor, depending on their magnitude, with expansion anchor bolts.

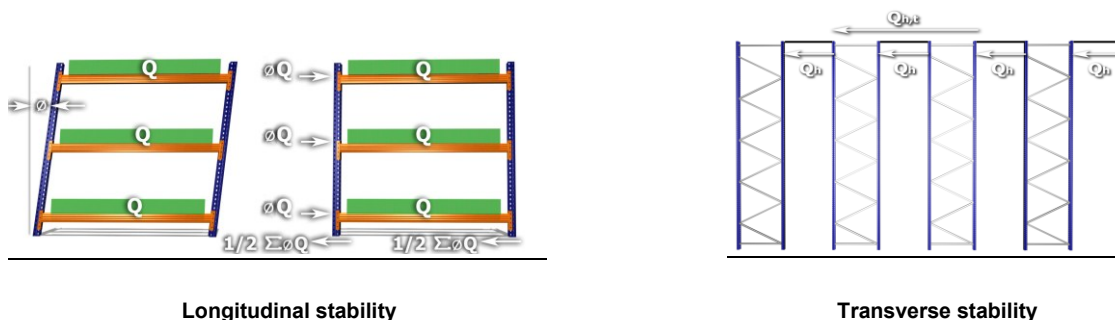

Longitudinal stability

Transverse stability

Load assumptions have been defined according to the directives in standard EN 15512 and the aforementioned calculation conditions, while verifying the strains, deformations, and longitudinal and transverse stability in consideration of the permanent and variable loads acting on the structure.

The maximum allowable deformation in beams is set to 1/200th of their length (L/200), in accordance with the indications of standard EN 15620.

Furthermore, the maximum allowable lateral deformation or displacement for the system's uprights is fixed at 1/200th of their height (H/200), according to the same standard.

To a large degree the safety of the racking system will depend on the characteristics, physical condition and evenness of the surface where it is installed. According to European standard EN 15629, it is essential that the floor can support the planned loads and intended use. The customer must ensure the floor meets the requirements for the particular project.

#### 4. LOADING CAPACITIES

H (mm)	Allowable load per frame (kg)				
	80x63x1.8	100x63x1.8	100x100x1.5	100x100x1.8	100x100x2.0
500	12,470	13,809	16,284	20,439	23,567
1,000	11,943	13,450	15,890	19,941	22,981
1,100	11,796	13,350	15,780	19,801	22,816
1,200	11,634	13,240	15,659	19,648	22,637
1,300	11,459	13,120	15,527	19,482	22,441
1,400	11,269	12,991	15,385	19,303	22,230
1,500	11,066	12,852	15,233	19,110	22,004
1,600	10,848	12,704	15,070	18,904	21,761
1,700	10,616	12,546	14,896	18,685	21,504
1,800	10,371	12,378	14,712	18,453	21,230
1,900	10,111	12,201	14,518	18,207	20,941
2,000	9,837	12,015	14,313	17,948	20,636
2,100	9,549	11,819	14,097	17,675	20,316
2,200	9,248	11,613	13,871	17,390	19,980
2,300	8,932	11,398	13,635	17,091	19,628
2,400	8,602	11,173	13,388	16,779	19,261
2,500	8,252	10,938	13,130	16,453	18,878
3,000	6,328	9,623	11,684	14,626	16,279
4,000	-	-	8,004	9,976	11,259

H = the greater value between the buckling height (distance between the floor and the first level) and the distance between loading levels

#### Nominal load capacity of frames

The loading capacities for frames presented in the previous table are limited not only by the load units, but also by the distance between levels, the buckling height (measured from the floor to the first level), the self-weight of the beams in all the loading levels and, where applicable, the accessories installed on the levels (beams, wood or fibreboards, bar gratings, retainers, stops, grills, fall arrest netting, etc.).

In addition, the self-weight of the load-bearing elements (metal panels, wood or fibreboards, bar gratings, etc.) must be subtracted from the maximum loads of goods to be placed on each level (pair of beams) indicated in the following table. Maximum loads per level will also depend on the total number of levels allowed in function of the frame configuration's total load capacity, the reduction associated with the weight and the use of the overhead loft installed.

**Allowable load per pair of beams (kg)**

Length	80x50x1.5	100x40x1.5	100x50x1.5	120x40x1.5	120x50x1.5	140x50x1.5
1,350	4,569	-	-	-	-	-
1,900	3,320	3,360	4,335	4,160	-	-
2,300	2,290	2,858	3,610	3,511	-	-
2,710	1,664	2,502	2,730	3,053	3,870	4,618
3,350	1,080	1,682	1,770	2,538	2,660	3,780
3,650	910	-	1,490	-	2,240	3,180
3,950	780	-	1,270	-	1,920	2,720

**Load capacity per level (pair of beams)  
Maximum loads uniformly distributed over two beams. Maximum deflection l/200**

In light of the above, the load-bearing capacities reflected in the previous two tables must be taken as preliminary and only for reference purposes, given that they will be adjusted according to load and usage limitations which, in any case, must be determined and observed in each project designed by Estanterías Record. In function of these limitations, the result of calculations will take priority, regardless of the nominal load capacity expressed in the above tables.

## 5. GUARANTEE

Estanterías Record, S.L. guarantees the supplied materials against all manufacturing and assembly defects for a period of 5 YEARS, so long as installation and maintenance services are performed by teams allocated by Estanterías Record.

In the event these circumstances are not met, the period of guarantee will be 1 year and will only cover manufacturing defects in the elements that constitute the storage system.

If assembly is contracted through Estanterías Record, the start date of this guarantee period will be taken as the date when assembly is completed and handover of the storage system is approved. However, if it is assembled by a third party, then the guarantee period will start from the materials delivery date. In either case, the term will elapse regardless of whether or not the storage system is put to use.

This guarantee only extends to the materials supplied for each specific storage system and is only valid under the following circumstances:

- All of Estanterías Record's instructions contained in the documentation provided to the customer and manuals delivered with the storage system have been followed.
- The storage system has been used in compliance with the original design and intended use, and within the levels of service for which it has been configured pursuant to the specifications in the accepted offer.
- The storage system must be free from any modifications or alterations to the initial assembly, design, function or application, and substitutions or repairs to any components, unless they have been performed with Estanterías Record's prior written consent.
- Appropriate maintenance and technical inspections, as recommended by Estanterías Record, have been completed.

- Any defects detected by the customer must be reported within a maximum of 24 hours, this includes damage or circumstances that could compromise the storage system's stability; furthermore, the customer must have followed any instructions relating to the matter provided by Estanterías Record.
- The customer has fulfilled all the obligations and responsibilities they must undertake pursuant to the contractual relationship.

During this guarantee period Estanterías Record will repair or replace any components that present serious manufacturing or assembly defects. Normal wear and tear resulting from the system's use and the passage of time are not covered by this guarantee. Repairs will be carried out in the shortest time possible and in accordance with the availability of the necessary personnel.

This guarantee will cover the replacement materials and costs of labour. Withdrawn materials will become the property of Estanterías Record.

The following points are excluded from the guarantee will be invoiced separately:

- The materials and labour used to repair or replace materials damaged as a result of their exposure to aggressive, corrosive, inappropriate or exceptional environments that were not originally planned for. Similarly, the guarantee will not extend to elements or the repair of storage systems located outdoors or subject to the action of atmospheric agents or meteorological phenomena.
- The materials and labour required to resolve damage caused by third parties due to inappropriate use or maintenance, the negligence of warehouse operatives or modifications on the storage system performed without Estanterías Record's consent.
- Interventions to repair damage caused by blows, fire, water, theft, exceptional occurrences or any other acts of God or force majeure.

## 6. STANDARDISATION AND CERTIFICATIONS

The technical report referred to the reference standards for the calculation and development of storage systems designed by Estanterías Record.

These assemblies are load-bearing metal structures for storing goods with various means of access and logistics management. As stated previously, the assembly of the system's basic components, uprights and beams, using specific connectors, produces three-dimensionally stable structures with intervening aisles that provide access to the storage locations. The main components, while they are only standard pieces for each manufacture, differ from traditional gantry structures, with regards to the standardisation of their design, because the uprights are perforated along their entire length, connections are made with coupling fixtures and their structural elements are generally made from thin-walled, cold-formed sections.

Due to the design characteristics of the structural components, details and types of connection, the EN standards require further technical information in addition to requirements demanded by the Eurocodes. The Eurocodes are universal European regulations drafted under consensus based on the interests of the national administrations with respect to each point and therefore they have a higher status than national regulations; they are designed as a comprehensive and updated framework for structural design and are applicable to storage systems.

The European standards (EN) are developed by CEN technical committees (TCs) whose scope is to establish the EN reference standards for the specification, design, installation methods and accuracy in assembly, while also serving as a safety guide for storage system users.

When this is combined with the need for harmonised standards it explains why the European Materials Handling Federation (FEM) decided to take the initiative from Technical Committee CEN/TC 344, Steel static storage systems, and draft a number of European standards regarding specific types of storage system and

their particular applications; these now exist as European standards (EN) and working group (WG) activities. CEN/TC 344 Steel static storage systems is directly related to CEN/TC 250 Structural Eurocodes, CEN/TC 135 Execution of steel structures and aluminium structures and CEN/TC 149 Power-operated warehouse equipment. *Safety.*

Since the storage system is a load-bearing structure, there are national regulations that require it to be considered “work equipment” and consequently it must comply with European Directive 89/391/EEC, on the introduction of measures to encourage improvements in the safety and health of workers at work.

Lastly, all of these regulations must be applied in accordance with the provisions of standards EN 1990 Basis of structural design, EN 1991 Actions on structures and EN 1993 Design of steel structures.

The numerical values applicable to the partial safety factors provide an acceptable level of certainty, assuming the work is executed in accordance with appropriate quality standards.

Estanterías Record strictly fulfils the technical regulations applicable to the design and supporting calculations for our products and services. What is more, our business processes conform to mandatory sectoral, national and international regulations as they comply with applicable guidelines regarding normalisation and legislation.

Furthermore, we systematically apply the directives laid down by ISO 9001:2008 concerning quality control, assurance and management systems to our procedures involving design, development, manufacturing, installation and after-sales service. Our company registration certificate is issued by TÜV International Rheinland, under licence for use number 0.04.03229. TÜV performs regular follow-up audits to ensure the operational performance of our ISO system and verify the aforementioned standard is implemented correctly.

As approved systems must meet the highest technical demands in terms of design, guidelines for testing, calculation, manufacturing, etc., then it culminates in more solid and reliable structures. This contributes to increased safety for the stored goods and above all it is beneficial for the storage system’s end user because it will minimise handling risks in day-to-day warehouse management.

The possession of a storage system developed according to the strictest regulations applicable implies a high degree of security and confidence in the event of demands for accountability or other procedural matters involving insurance companies, financial entities, public bodies, health and safety inspections, etc.

Finally, Estanterías Record is a member of the FEM-AEM. The purpose of the FEM-AEM (Spanish Material Handling Association) is to collaborate with national and EU bodies in matters concerning the regulation, improvement and unification of its sector, while also cooperating with partner countries and European manufacturers.

As explained above, Estanterías Record is evidently very committed and engaged in terms of meeting the sector’s most stringent requirements so we can offer the market products of the highest quality, safety and guarantee.



## 7. AFTER-SALES SERVICES

Storage systems suffer wear and tear through continuous or incorrect use, thereby reducing the functionality and load-bearing capacity for which they were designed, and significantly increasing the risk of accidents. Damaged components or which have received blows, even though the damage may not be visible, can generate dangerous stresses that could even result in its, occasionally, instantaneous and sudden collapse.

The user is responsible for ensuring that their storage system is in good condition and proper working order. To assist in this respect, Estanterías Record can, upon request, provide their customers an inspection and revision service for the installed equipment in order to carry out appropriate preventive or corrective maintenance and minimise these risks.

Additionally, we can: offer our customers advice on the correct use of their storage system regarding safety or what to do in case of accidents; provide them with technical and training manuals covering maintenance; monitor and assess preventive maintenance tasks carried out by the user; perform any corrective interventions that may be required, etc.

Standard EN 15635 concerning "Steel static storage systems. Application and maintenance of storage equipment" establishes the need for storage systems to be inspected at least once a year by an external professional expert.

Given the important consequences that could result from this situation, Estanterías Record recommends that users take note of the above and act diligently in this regard.